

ARMY
NAVY
AIR FORCE

TM 11-6625-3023-14
ET904-AA-MMA-010/E154 TS3684
TO 33A1-12-1173-1

TECHNICAL MANUAL

OPERATOR'S, ORGANIZATIONAL,
DIRECT SUPPORT AND GENERAL SUPPORT

MAINTENANCE MANUAL

FOR

TEST SET

ELECTRIC SURGE ARRESTORS

TS-3684/T

DEPARTMENTS OF THE ARMY, NAVY, AND AIR FORCE

31 JANUARY 1983



5

SAFETY STEPS TO FOLLOW IF SOMEONE IS THE VICTIM OF ELECTRICAL SHOCK

1

DO NOT TRY TO PULL OR GRAB THE INDIVIDUAL

2

IF POSSIBLE, TURN OFF THE ELECTRICAL POWER

3

IF YOU CANNOT TURN OFF THE ELECTRICAL POWER, PULL, PUSH OR LIFT THE PERSON TO SAFETY USING A DRY WOODEN POLE OR A DRY ROPE OR SOME OTHER INSULATING MATERIAL

4

SEND FOR HELP AS SOON AS POSSIBLE

5

AFTER THE INJURED PERSON IS FREE OF CONTACT WITH THE SOURCE OF ELECTRICAL SHOCK, MOVE THE PERSON A SHORT DISTANCE AWAY AND IMMEDIATELY START ARTIFICIAL RESUSCITATION

WARNINGS

Adequate ventilation should be provided while using TRICHLOROTRIFLUOROETHANE. Prolonged breathing of vapor should be avoided. The solvent should not be used near heat or open flame; the products of decomposition are toxic and irritating. Since TRICHLOROTRIFLUOROETHANE dissolves natural oils, prolonged contact with skin should be avoided. When necessary, use gloves which the solvent cannot penetrate. If the solvent is taken internally, consult a physician immediately.

HIGH VOLTAGE

is used in this equipment.

Be careful when working near the interior of the equipment, or near the ac power distribution. Observe warning notes in this technical manual and warning decals on equipment. Death on contact may result if safety precautions are not observed.

Compressed air shall not be used for cleaning purposes except where reduced to less than 1/29 pounds per square inch (psi) and then only with effective chip guarding and personnel protective equipment. Do not use compressed air to dry parts when TRICHLOROTRIFLUOROETHANE has been used. Compressed air is dangerous and can cause serious bodily harm if protective means or methods are not observed to prevent chip or particle (of whatever size) from being blown into the eyes or unbroken skin of the operator or other personnel.

A

TECHNICAL MANUAL
NO. 11-6625-3023-14
TECHNICAL MANUAL
ET904-AA-MMA-010/E154 TS3684
TECHNICAL ORDER
TO 33A1-12-1173-1

TM 11-6625-3023-14
ET904-AA-MMA-010/E154 TS3684
TO 33A1-12-1173-1

DEPARTMENTS OF THE ARMY
THE NAVY, AND THE AIR FORCE
WASHINGTON, DC 31 JANUARY 1983

**OPERATOR'S, ORGANIZATIONAL,
DIRECT SUPPORT AND GENERAL SUPPORT
MAINTENANCE MANUAL
FOR
TEST SET, ELECTRIC SURGE ARRESTORS
TS-3684/T**

REPORTING ERRORS AND RECOMMENDING IMPROVEMENTS

You can help improve this manual. If you find any mistakes or if you know of a way to improve the procedures, please let us know. Mail your letter, DA Form 2028 (Recommended Changes to Publications and-Blank Forms), or DA Form 2028-2 located in back of this manual direct to: Commander, US Army Communications - Electronics Command and Fort Monmouth, ATTN: DRSEL-ME-MP, Fort Monmouth, New Jersey 07703.

For Air Force, submit AFTO Form 22 (Technical Order System Publication Improvement Report and Reply) in accordance with paragraph 6-5, Section VI, T.O. 00-5-1. Forward direct to prime ALC/MST.

For Navy, mail comments to the Commander, Naval Electronics Systems Command, ATTN: ELEX 8122, Washington, DC 20360.

In either case, a reply will be furnished direct to you.

TABLE OF CONTENTS

		Paragraph	Page
CHAPTER	1.	INTRODUCTION	
Section	I.	General	1-1
	II.	Description and Data	1-8
CHAPTER	2.	SERVICE UPON RECEIPT AND INSTALLATION	
Section	I.	Service Upon Receipt of Material	2-1
	II.	Installation Instructions	2-3
CHAPTER	3.	OPERATING INSTRUCTIONS	
Section	I.	Controls and Indicators	3-1
	II.	Operation	3-3
CHAPTER	4.	FUNCTIONAL DESCRIPTION	4-1
CHAPTER	5.	ORGANIZATIONAL MAINTENANCE INSTRUCTIONS	5-1
CHAPTER	6.	GENERAL SUPPORT MAINTENANCE	
Section	I.	General	6-1
	II.	Troubleshooting	6-3
	III.	Repair	6-5
APPENDIX	A.	REFERENCES	A-1
APPENDIX	B.	MAINTENANCE ALLOCATION	
Section	I.	Introduction	B-1
	II.	Maintenance Allocation Chart for Test Set, Electric Surge Arrestors TS-3684(T)	B-3
	III.	Tool and Test Equipment Requirements for Test Set, Electric surge Arrestors TS-3684(T)	B-3
	IV.	Remarks	B-4
APPENDIX	C.	COMPONENTS OF END ITEM LIST	
Section	I.	Introduction	C-1
	II.	Integral Components of End Item	C-3
	III.	Basic Issue Items (Not applicable)	
APPENDIX	D.	ADDITIONAL AUTHORIZATION LIST (Not applicable)	
APPENDIX	E.	EXPENDABLE SUPPLIES AND MATERIALS LIST	
Section	I.	Introduction	E-1
	II.	Expendable Supplies and Materials List	E-2

CHAPTER 1

INTRODUCTION

Section I. GENERAL

1-1. Scope. This manual describes the Test Set, Electric Surge Arrestors TS-3684/T (fig. 1-1), hereafter referred to as the ESA test set. The manual contains information on the functioning of equipment, installation and operation. The manual also provides organizational and general support maintenance instructions, including troubleshooting, repair and calibration. A complete listing of reference publications is provided in Appendix A. The Maintenance Allocation Chart is contained in Appendix B. The Repair Parts and Special Tools List (RPSTL) is contained in TM 11-6625-3023-24P.

1-2. Consolidated Index of Army Publications and Blank Forms,

a. Army. Refer to the latest issue of DA Pam 310-1 to determine whether there are new editions, changes or additional publications pertaining to the equipment.

b. Air Force. Use T.O. 0-1-31 Series Numerical Index and Requirements Table (NIRT).

1-3. Maintenance Forms, Records and Reports.

a. Reports of Maintenance and Unsatisfactory Equipment. Department of the Army forms and procedures used for equipment maintenance will be those prescribed by TM 38-750, The Army Maintenance Management System (Army). Air Force personnel will use AFR 66-1 for maintenance reporting and TO-00-35D54 for unsatisfactory equipment reporting. Navy personnel will report maintenance performed utilizing the Maintenance Data Collection Subsystem (MDCS) IAW OPNAVINST 4790.2, Vol 3 and unsatisfactory material/conditions (UR submissions) IAW OPNAVINST 4790.2, Vol 2, chapter 17.

b. Report of Packaging and Handling Deficiencies. Fill out and forward SF 364 (Report of Discrepancy (ROD)) as prescribed in AR 735-11-2/DLAR 4140.55/NAVMATINST 4355.73/AFR 400-54/MCO 4430.3E.

c. Discrepancy in Shipment Report (DISREP)- (SF 361). Fill out and forward Discrepancy in Shipment Report (DISREP) (SF 361) as prescribed in AR 55-38/NAVSUPINST 4610.33B/AFR 75-18/MCO P4610.19C/DLAR 4500.15.

1-4. Hand Receipt (-HR) Manuals. This manual has a companion document with a TM number followed by "-HR" (which stands for Hand Receipt). The TM 11-6625-3023-14-HR consists of preprinted hand receipts (DA Form 2062) that list end item related equipment (i.e., COEI, BII, and AAL) you must account for. As an aid to property accountability, additional -HR manuals may be requisitioned from the US Army Adjutant General Publications Center in Baltimore, MD, in accordance with the procedures in Chapter 3, AR 310-2, and DA Pam 310-10-2.

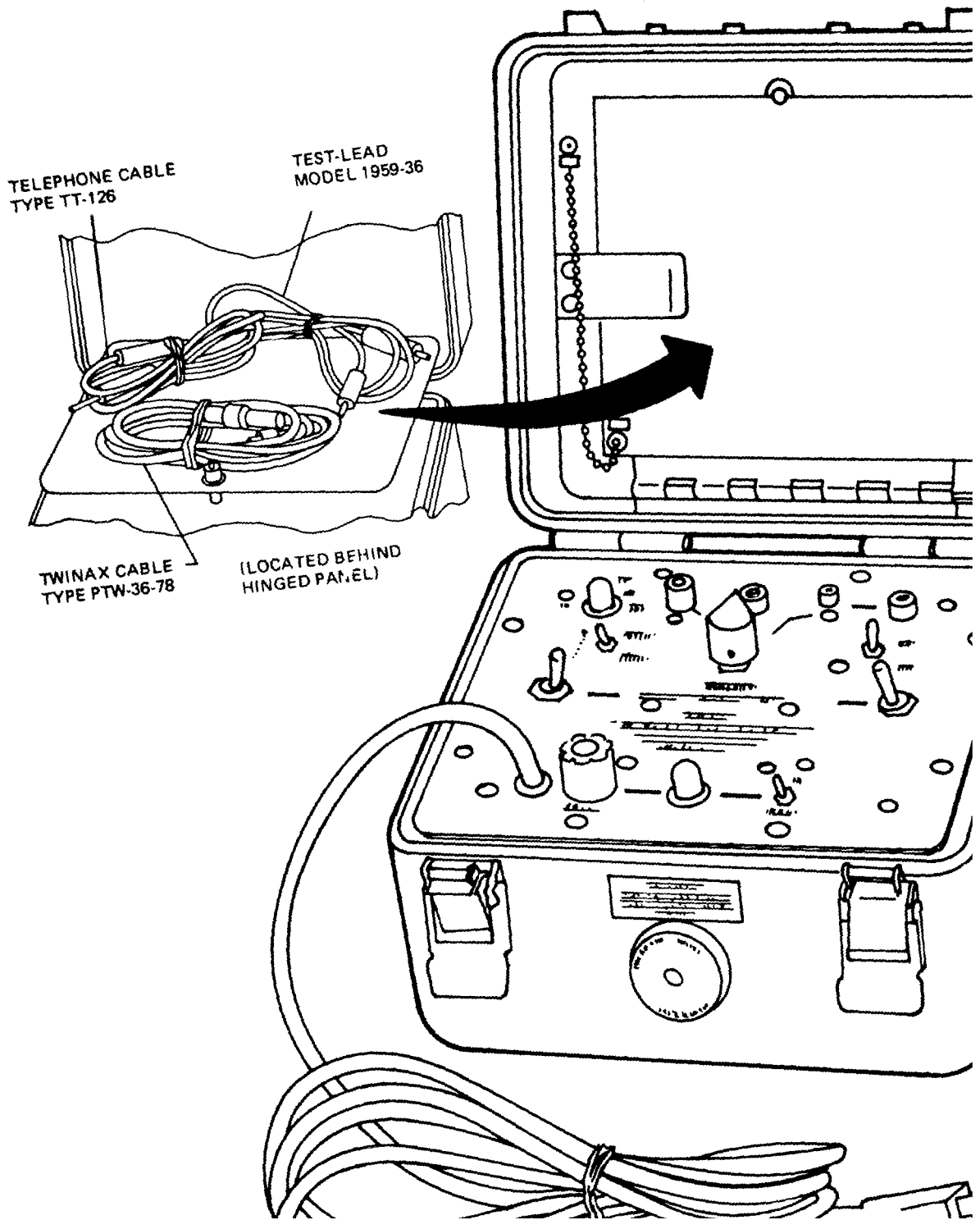

Figure 1-1. Test Set, Electric Surge Arrestors, TS-3684/T

1-5. Reporting Equipment Improvement Recommendations (EIR).

a. Army. If your ESA Test Set TS-3684/T needs improvement, let us know. Send us an EIR. You, the user, are the only one who can tell us what you don't like about your equipment. Let us know why you don't like the design. Put it on an SF 368 (Quality Deficiency Report). Mail it to Commander, US Army Communications-Electronics Command and Fort Monmouth, ATTN: DRSEL-ME-MP, Fort Monmouth, New Jersey 07703. We'll send you a reply.

b. Air Force. Air Force personnel are encouraged to submit EIR's in accordance with AFR 900-4.

c. Navy. Navy personnel are encouraged to submit EIR's through their local Beneficial Suggestion Program.

1-6. Administrative Storage. Administrative storage of equipment issued to and used by Army activities will have preventive maintenance procedures performed in accordance with paragraph 5-3 of this manual. When removing the equipment from administrative storage, routine checks should be performed to assure operational readiness.

1-7. Destruction of Army Electronics Materiel. Destruction of Army electronics materiel to prevent enemy use shall be in accordance with TM 750-244-2.

Section II. DESCRIPTION AND DATA

1-8. Purpose and Use. The Test Set TS-3684/T provides a means of checking the performance of electric surge arrestors (ESA); gas-filled surge/transient voltage protectors, such as bulk devices and those associated with coaxial lines; and engineering order wire (EOW) lines

1-9. Description. The test set consists of a panel assembly and a printed circuit board assembly mounted in an aluminum alloy case with a carrying handle. A hinged cover permits access for connection of a power cord and ESA test cables. The panel assembly includes all controls, indicators, and connections for operating the test set. Three ESA test cables are stored behind a drop-down panel located inside the hinged cover of the case. The hinged cover also provides storage for a plastic laminated operation instruction card. The panel-mounted components are secured in the case against moisture and dust by a combination seal when the latches are locked. A pressure relief knob located on the front of the case is provided to equalize internal and external pressures.

1-10. Technical Characteristics.

- a. Power.
Input voltage: 115 Volts AC
50, 60, or 400 Hz
Single phase

- b. Environmental Characteristics.
Temperature (operating): 0 degrees F to +125 degrees F
Temperature (nonoperating): 0 degrees F to +160 degrees F
Humidity: 0 to 100 percent
Altitude (operating): Sea level to 10, 000 feet
Altitude (nonoperating): Sea level to 40, 000 feet

1-11. Items Comprising an Operable Equipment. The items comprising an operable equipment are listed in table 1-1.

Table 1-1. Major Item Configuration

Part or identifying no.	Item	Dimensions (in.)			Weight (lb)	
		Qty.	Height	Depth		Width
	Test Set, Electric Surge Arrestors TS-3684/T, consisting of:		6 1/2	8	8 1/4	7
84003753	Operation Instruction Card	1				
17238	Power Cord	1				
Type TT-126	Test Cable Assembly, 3-ft., Telephone Type Plug, Switchcraft Inc.	1				
Type PTW-36-78	Test Cable Assembly, 3-ft., TWINAX Cable, Trompeter Electronic Inc.	1				
Model 1959-36	Test-Lead with booted alligator clip and banana plug ends, ITT Pomona Electronics	1				

1-5/(1-6 blank)

CHAPTER 2

SERVICE UPON RECEIPT AND INSTALLATION

Section I. SERVICE UPON RECEIPT OF MATERIAL

2-1. Unpacking. No special instructions are required for unpacking the test set. Remove the test set from its shipping container and perform the inspection given in paragraph 2-2.

2-2. Checking Unpacked Equipment.

- a. Inspect the equipment for damage incurred during shipment. If equipment has been damaged, report the damage on SF 364 (para 1-3b).
- b. Check the equipment against the component listing on the packing slip to see if the shipment is complete. Report all discrepancies in accordance with paragraph 1-3c. The equipment should be placed in service even though a minor assembly or part that does not affect proper functioning is missing.
- c. Check to see whether the equipment has been modified. Equipment which has been modified will have the MWO number on the front panel near the nomenclature plate. Refer to DA Pam 310-14 to see whether all currently applicable MWOs have been applied.

Section II. INSTALLATION INSTRUCTIONS

2-3. Introduction. The electric surge arrestors (ESA) test set is a portable, self-contained test unit which does not require permanent installation. The test set is used prior to the operation of equipment that has been relocated, and periodically at specific predetermined intervals. This section contains the procedure for interconnection of the ESA test cables and preliminary checks of the test set. No special tools or test equipment are required.

2-4. Test Set Preliminary Check.

- a. Place the unit on a level surface which will allow the operator sufficient access to perform his functions.
- b. Depress the pressure relief valve located on the front of the equipment case (fig. 1-1), before opening lid, to equalize internal and external pressures.
- c. Release the two front latches and lift the hinged lid.
- d. Perform test operating instructions described in chapter 3.

2-5. Electrical Interconnection. The three test cables located in the cover compartment are supplied to test the bulk, coaxial, or end of wir (EOW) line type ESA devices. Refer to chapter 3, section II, Operation for the electrical interconnection to the particular ESA to be tested.

2-1/(2-2 blank)

CHAPTER 3

OPERATING INSTRUCTIONS

Section I. CONTROLS AND INDICATORS

3-1. Introduction. This section presents the operating instructions for the test set and includes the functions of all operating controls and indicators.

3-2. Controls and Indicators. The test set controls and indicators are shown in figure 3-1 and functionally described in table 3-1.

Section II. OPERATION

3-3. Introduction. This section provides the operating procedures for the test set. These procedures consist of the test set operational check and the operating instructions for checking the performance of the bulk, coaxial and EOW line ESA devices. Maintenance schedules require that each signal line ESA device be tested upon initial installation prior to operation of a system that has been relocated and also tested periodically at specific predetermined intervals.

NOTE

The operational procedures described herein apply to the AN/TTC-39 System as well as to other systems containing electric surge arrestors. See references in Appendix A for specific details when testing electric surge arrestors in the AN/TTC-39 System.

3-4. Test Set Operational Check.

- a. Equipment Required. A digital multimeter or equivalent.

WARNING

Test set ground is provided through the third wire of the AC power cord. The test set must be powered from the system under test or a lethal voltage potential could be developed between the hardware and the ESA test set case.

- b. Procedure.

- (1) Connect test set power cord into a 115 VAC (50, 60, or 400 Hz) power outlet within the system under test.
- (2) Turn POWER switch to ON position. The red lamp should light. If it does not, refer to paragraph 5-6.
- (3) Perform lamp test by placing TEST switch in SHORT position and press the two momentary TEST toggle switches simultaneously. The green lamp should light.

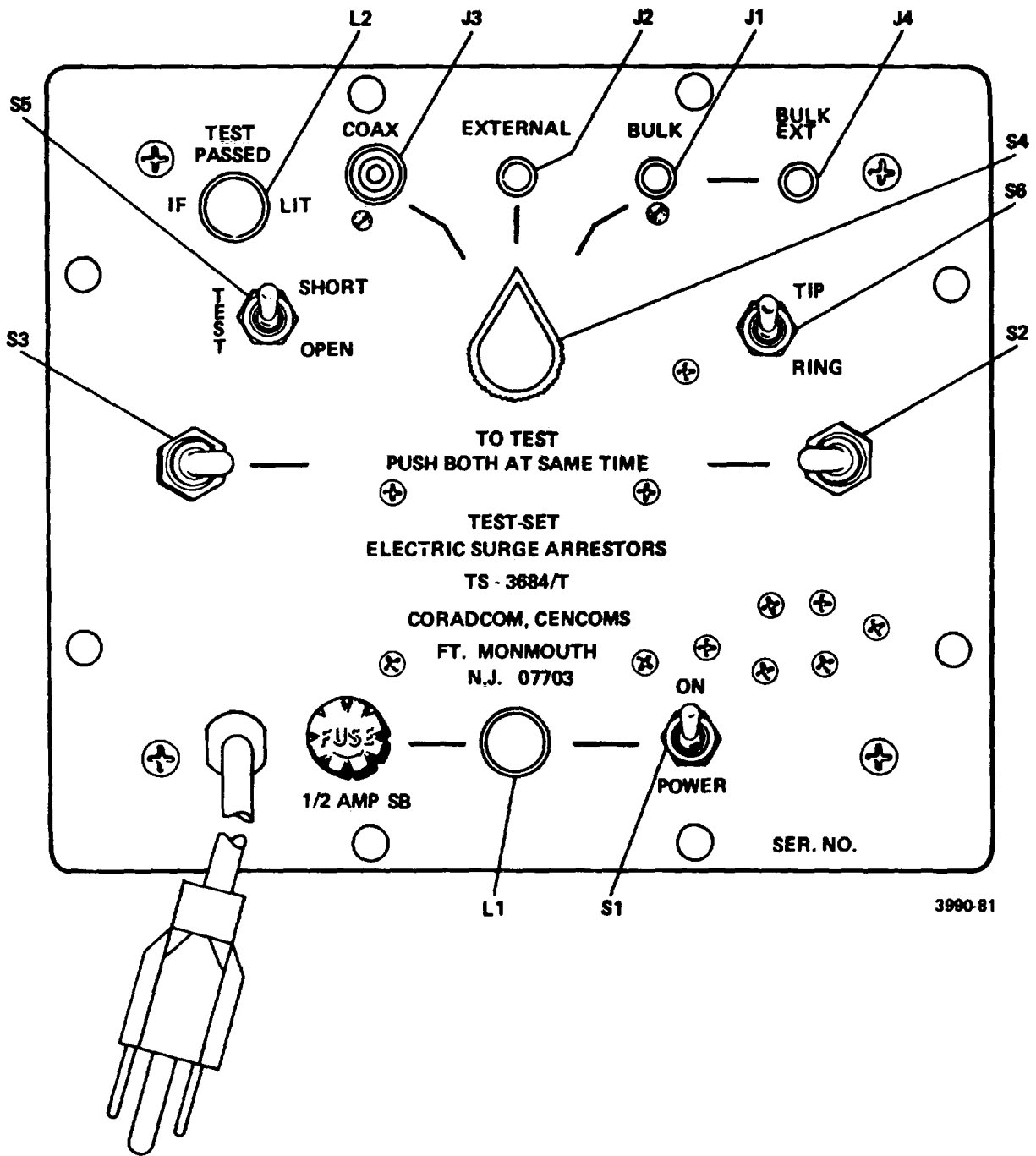

Figure 3-1. Test Set TS-3684/T Controls and Indicators

Table 3-1. Test Set, Controls and Indicators

Control/indicator	Function
POWER ON/OFF switch (S1) (SPST toggle)	Applies 115 VAC, 50, 60 or 400 Hz to test set in the ON position.
TEST switches (S2, S3) (momentary toggle switches)	When both TEST switches are depressed, the current path to the zener diodes (D3 and D4) energizes the selected output connector BULK (J1), EXTERNAL (J2) or COAX (J3).
ESA select switch (S4) (rotary)	Applies the test voltage to the proper connector (BULK (J1), EXTERNAL (J2), COAX (J3)) of the particular ESA unit to be tested.
TEST switch (S5) SHORT or OPEN (DPDT toggle)	Places lamp L2 in parallel with ESA device for the SHORT test and in series with the ESA device for the OPEN test.
Switch, TIP or RING (S6) (DPDT toggle)	Enables selection of either the TIP or RING wire of the transmission line pairs (see note). In testing BULK units it is only needed when checking every wire of the unit for a shorted condition since the OPEN test on one associated wire checks the entire unit.
TEST PASSED IF LIT (L2) indicator (green)	Illuminates to indicate a passed test.
AC power ON (L1) indicator (red)	Illuminates when 115 Volts, 50, 60 or 400 Hz is applied to test set power supply circuit.

NOTE

Telephone Plug



- (4) Connect the red booted alligator test lead, supplied with the test set, into the jack marked BULK-EXT.
- (5) Connect the test lead to the voltage probe of the digital multimeter.

CAUTION

Be sure that the test lead and the meter probe do not touch any part of the metal of the test set. Place the connection on an insulated surface.

- (6) Connect the common lead of the multimeter to earth ground. A common connection may be obtained on any metal of the panel switches and jacks, such as the sleeve of the BULK telephone jack.
- (7) Set multimeter to the 1000 VDC scale.
- (8) Set TEST switch in the OPEN position.
- (9) Set rotary switch in the BULK position.
- (10) Set TIP-RING switch in the TIP position.
- (11) Press the momentary toggle switches at the same time.
- (12) The multimeter should read 500 VDC +8% (see note). If it does not, the test set is out of specification and should be sent for repair. See chapter 6, General Support Maintenance.
- (13) Move the red booted alligator test lead from the BULK-EXT jack to the EXTERNAL jack.
- (14) Set multimeter to the 300 VDC scale.
- (15) Set rotary switch to the EXTERNAL position.
- (16) Press the two momentary toggle switches at the same time.
- (17) The multimeter should read 140 VDC +8% (see note). If it does not, the test set is out of specification and should be sent for repair. See chapter 6, General Support Maintenance.

NOTE

The tolerance allows for the meter accuracy and the effect of slight heating of the zener diodes.

CHAPTER 4

FUNCTIONAL DESCRIPTION

4-1. Introduction. This chapter provides the functional description of the test set. A brief description of the electric surge arrestors (ESA) devices is presented first, followed by a general overall functional and detailed circuit description of the test set.

4-2. Signal ESA Theory. The TS-3684/T Test Set is capable of checking three different types of ESA devices: bulk devices and those associated with coaxial (digital transmission) lines, intercom and EOW lines. The ESA devices conduct whenever the voltage across them exceeds a particular threshold (ionization potential). Each individual transmission wire has an ESA device connected between it and earth ground at the point-of-entry to the equipment. Prior to conducting, the ESA device exhibits a high impedance which is negligible to a transmission system. During conduction the device has a very low impedance and therefore shunts the surge energy to ground, thereby limiting the stress to subsequent electronic components. A brief description of the three types of ESA devices is as follows:

- a. Bulk
 - All conductors are protected by a common gas (tritium) chamber which ionizes and shunts all the conductors if the threshold voltages (350 Volts, nominal) are exceeded on any signal conductor.

- b. Coaxial intercom and end of wire (EOW) lines
 - Conductors are protected by individual button-like gas filled devices built into a high voltage assembly. These devices have a 90-Volt nominal threshold voltage.

4-3. Test Set Functional Description (fig. FO-2).

a. General. The test set consists of a transformer-coupled, voltage-doubler, current-limited regulated power supply capable of operating from a power source of 105 to 130 VAC of either 50, 60 or 400 Hz. Switches are provided for device selection (bulk, coax or external EOW), type of test (SHORT or OPEN), and TIP-RING selection, in addition to two momentary toggle switches to initiate testing.

The SHORT test consists of placing an incandescent lamp in parallel with the ESA device being tested. If the arrestor is good (not excessively leaky or shorted), all the available current will flow through the lamp, causing it to light. If the arrestor is shorted or has an abnormally low impedance, the lamp will not be able to light because most of the current will flow through the arrestor.

The OPEN test consists of placing the incandescent lamp in series with the ESA device being tested. If the arrestor is good (has an ionization threshold below the applied test voltage), it will ionize, and the current that flows will light the lamp, giving a green indication. If the arrestor is open or has a breakdown threshold

(ionization potential) greater than the applied test voltage, the arrestor will not conduct and no current will be available to light the lamp.

The circuitry develops a voltage of 500 VDC +5 percent for testing the bulk ESA units and 140 VDC +5 percent for testing the coax and external (EOW and intercom protecting devices). These voltages represent the maximum allowable threshold voltage that the devices may have, respectively, to be considered acceptable.

During all tests the current supplied to the devices is limited to a maximum of 16 milliamperes.

b. Detailed Functional Description. The line voltage of 115 VAC (nominal) is stepped-up by transformer T1 and rectified by diodes D1 and D2, which, in conjunction with capacitors C1 and C2, form a voltage doubler. Approximately 760 VDC (no load) is developed across R1.

During testing (momentary toggle switches S2 and S3 depressed), approximately 15 milliamperes DC flows through R2 or R2 and R3, depending on the position of the device selection switch, S4.

Resistor R2 in conjunction with zener diodes, D3 and D4 (acting in series), form a 500 VDC +5 percent voltage regulator for testing the bulk ESA devices. R2 and R3 (acting in series) in conjunction with zener diode, D4, form a 140 VDC +5 percent voltage regulator for testing the coax and external (EOW and intercom protecting) devices.

Resistors R4 and R5 are current-limiting resistors employed only during the SHORT test.

Switches S2 and S3 are momentary toggle switches, both of which must be depressed to complete the current path to the zener diodes and subsequently energize the selected output connector (either J1, J2, or J3).

Switch S4 is a rotary switch which directs the test voltage to the proper connector J1 through J3 for the particular ESA unit to be tested.

Switch S5 places lamp L2 (R4 and R5 are used in series with L2) in parallel with the ESA device for the SHORT test and in series with the ESA device for the OPEN test.

Switch S6 enables selection of either the TIP or RING wire of the transmission line pairs. In testing bulk units it is only needed when checking every wire of the unit for a shorted condition (as in initial installation), since the OPEN test on one associated wire checks the entire unit.

CHAPTER 5

ORGANIZATIONAL MAINTENANCE INSTRUCTIONS

5-1. Introduction. This chapter contains the maintenance instructions for the ESA test set. They include routine checks, preventive maintenance services, general cleaning instructions, troubleshooting and removal and replacement procedures.

Organizational maintenance of the test set is limited to replacement of indicator lamps and fuse. Other maintenance procedures must be performed at general support maintenance.

5-2. Tools and Equipment. The tools and test equipment allocated for maintenance on the test set are listed in the maintenance allocation chart in appendix D. There are no special tools or test equipment required for maintenance of the test set.

5-3. Preventive Maintenance Procedures.

a. General. Operator and organizational preventive maintenance is the systematic care, servicing, and inspection of equipment to prevent the occurrence of trouble, to reduce downtime, and to maintain the equipment in serviceable condition. Defects that cannot be corrected must be reported to higher category maintenance personnel.

b. Routine Checks. Routine checks such as cleaning, dusting, washing, checking for frayed cables, stowing items not in use, covering unused receptacles and checking for loose nuts and bolts are not listed as preventive maintenance checks or services. These are things that you should do anytime you see they must be done to maintain equipment in serviceable condition.

c. Preventive Maintenance Checks and Services. Preventive maintenance checks of the test set are not required. However, before operating, perform lamp test by placing TEST switch in SHORT position and press the two momentary TEST toggle switches simultaneously. The green lamp should light.

5-4. Cleaning.

WARNING

USE OF CLEANING SOLVENT

Adequate ventilation should be provided while using TRICHLOROTRIFLUOROETHANE. Prolonged breathing of vapor should be avoided. The solvent should not be used near heat or open flame; the products of decomposition are toxic and irritating. Since TRICHLOROTRIFLUOROETHANE dissolves natural oils, prolonged contact with skin should be avoided. When necessary, use gloves which the solvent cannot penetrate. If the solvent is taken internally, consult a physician immediately.

a. General Cleaning. Use a dry, clean, lint-free cloth or brush to remove dust or dirt. If necessary, moisten the cloth or brush with trichlorotrifluoroethane (NSN 6850-00-105-3084). After cleaning, wipe dry with a clean cloth.

WARNING

Compressed air shall not be used for cleaning purposes except where reduced to less than 29 pounds per square inch (psi) and then only with effective chip guarding and personnel protective equipment. Do not use compressed air to dry parts when TRICHLOROTRIFLUOROETHANE has been used. Compressed air is dangerous and can cause serious bodily harm if protective means or methods are not observed to prevent chip or particle (of whatever size) from being blown into the eyes or unbroken skin of the operator or other personnel.

b. Compressed Air. Dry, compressed air, not to exceed 29 psi, may be used, unless otherwise indicated, to remove dirt and dust from inaccessible places.

5-5. Touch-up Painting. Remove rust and corrosion from metal surfaces by lightly sanding them with fine sandpaper. Brush two thin coats of paint on bare metal to protect it from further corrosion. Refer to the applicable cleaning and refinishing practices specified in TB 746-10.

5-6. Removal and Replacement.

a. Indicator Lamps. To replace the indicator lamps, unscrew the color lens. The lamp under the red lens (L1) is a neon lamp type NE-2D. The lamp under the green lens (L2) is a miniature incandescent type No. 344.

b. Fuse Replacement.

- (1) Replace the fuse if the red lamp fails to light after replacement. The fuse is a 1/2A SLO BLO, 3AG.
- (2) If the fuse continues to blow or the unit does not function, refer to chapter 6 for General Support maintenance.

CHAPTER 6

GENERAL SUPPORT MAINTENANCE

Section I. GENERAL

6-1. Introduction. This chapter provides instructions for general support level maintenance. General support level maintenance personnel perform corrective maintenance on the test set which was identified as faulty by organizational maintenance personnel, but was beyond their capability to correct using the maintenance resources authorized at the organizational maintenance level. General support level maintenance personnel also provide technical assistance to the using organization in all areas which require skills and training that are beyond the capabilities of the organizational maintenance personnel.

6-2. Tools and Test Equipment. Tools and test equipment required to perform the maintenance procedures given in this chapter are listed in the Maintenance Allocation Chart in appendix D. Refer to the Repair Parts and Special Tools List (RPSTL) TM 11-6625-3023-24P for identification of intermediate level items.

Section II. TROUBLESHOOTING

6-3. Introduction. This section provides information to aid in troubleshooting the test set. The troubleshooting concept is based on fault isolation to replace the panel-mounted components and circuit board components by general support level maintenance which cannot be resolved or repaired by organizational level maintenance.

6-4. Troubleshooting Procedures. Table 6-1 is a list of fault indications that may be encountered due to malfunctions of the test set. These fault indications may be observed while performing the operational procedures given in chapter 3. A performance check of the test set is provided in table 6-2. The test points indicated in the table are shown on the test set schematic diagram in-figure-FO-2. Use the wiring diagram shown in figure FO-3 to support this troubleshooting. A standard color coding chart (fig. FO-1) for component identification is included as an aid in troubleshooting.

Table 6-1 Test Set Troubleshooting

Fault indication	Probable cause	Corrective action
1. Test set is inoperative.	<ul style="list-style-type: none"> a. POWER switch off. b. Blown fuse. c. Diode rectifier(s) D1 and/or D2. d. Power cord and/or plug open. e. No 115 VAC power, f. Power switch S1 opens 	<ul style="list-style-type: none"> a. Turn POWER switch on. b. Replace fuse (F1). c. Replace diode rectifier(s) (para 6-21). d. Replace power cord (para 6-18). e. Check AC power f. Replace power switch (para 6-9).
2. Fuse (F1) blows when changed.	<ul style="list-style-type: none"> a. Transformer T1 has short or open winding, b. Diode rectifier D1 or D2 shorted. c. Filter capacitor C1 or C2 shorted 	<ul style="list-style-type: none"> a. Replace transformer T1 (para 6-12). b. Replace diode rectifier (para 6-21). c. Replace Filter capacitor (para 6-20).
3. AC POWER on lamp does not light	<ul style="list-style-type: none"> a. AC POWER switch off. b. Blown fuses c. AC POWER on switch. 	<ul style="list-style-type: none"> a. Turn AC POWER switch on. b. Replace fuse (F1). c. Replace AC POWER on switch (para 6-9).
4. TEST indicator does not light.	<ul style="list-style-type: none"> a. Indicator bulb defective. b. Defective lampholder. 	<ul style="list-style-type: none"> a. Replace indicator bulb (para 5-6). b. Replace lampholder (para 6-8).

Table 6-1. Test Set Troubleshooting - Continued

Fault indication	Probable cause	Corrective action
5. 280 VAC not present across test points B indicator lamp and D. Power L1 lights.	a. Transformer T1 primary or secondary winding open. b. Broken wire.	a. Replace transformer T1 (para 6-12). b. Check wiring for continuity.
6. +770 VDC ($\pm 5\%$) not present across test points C and A.	a. Diode rectifier D1 or D2 open. b. Filter capacitor C1 or C2 open. c. Broken wire,	a. Replace diode rectifier D1 or D2 (para 6-21). b. Replace filter capacitor C1 or C2 (para 6-20). c. Check wiring for continuity.
7. +770 VDC ($\pm 5\%$) not present across test points H and A.	a. Resistor R2 open (no voltage at test point H for all three positions of S4). b. Switch S4 open in EXTERNAL position. c. Resistor R3 open. d. Broken wire.	a. Replace resistor R2 (para 6-14). b. Replace switch S4 (para 6-11). c. Replace resistor R3 (para 6-14). d. Check wiring for continuity.
a. Switch S4 in BULK position (switches S2 and S3 not pressed).		
b. Switch S4 in EXTERNAL position (switches S2 and S3 not pressed).		
c. Switch S4 in COAX position (switches S2 and S3 not pressed).		

Table 6-1. Test Set Troubleshooting - Continued

Fault indication	Probable cause	Corrective action
<p>8. +500 VDC ($\pm 8\%$) not present across test points K and A (switches S2 and S3 pressed). Switch S4 in BULK position and switch S5 in OPEN position.</p>	<p>a. Zener diode D3 and/or D4 open or shorted.</p> <p>b. Switch S2 and/or S3 open (not closing),</p> <p>c. Broken wire.</p>	<p>a. Replace zener diode D3 and/or D4 and associated heat sink (para 6-10).</p> <p>b. Replace switch S2 and/or S3 (para 6-9).</p> <p>c. Check wiring for</p>
<p>9. +140 VDC ($\pm 8\%$) not present across test points L and A (switches S2 and S3 pressed). Switch S4 in EXTERNAL or COAX position and switch S5 in OPEN position.</p>	<p>a. Zener diode D4 open or shorted.</p> <p>b. Switch S2 and/or S3 open (not closing).</p> <p>c. Broken wire.</p>	<p>a. Replace zener diode D4 and associated heat sink (para 6-10).</p> <p>b. Replace switch S2 and/or S3 (para 6-9).</p> <p>c. Check wiring for continuity.</p>
<p>10. No voltage between test points E and A. Switches S2 and S3 pressed at the same time.</p>		
<p>a. Switch S4 in BULK position.</p>	<p>a, b, and c.</p>	<p>a, b, and c.</p>
<p>(1) Switch S5 in OPEN position. +500 VDC $\pm 8\%$ not present.</p>	<p>(1) Switch S5 defective. Lamp L2 open, Resistor R4 and/or R5 open.</p>	<p>Replace switch S5 (para 6-9). Replace lamp L2 (para 5-6). Replace resistor R4 and/or R5 (para 6-22).</p>
<p>(2) Switch S5 in SHORT position. +210 VDC $\pm 10\%$ not present.</p>	<p>(2) Switch S5 defective. Lamp L2 open, Defective wiring,</p>	<p>Check wiring for continuity.</p>

Table 6-1. Test Set Troubleshooting - Continued

Fault indication	Probable cause	Corrective action
<p>10 - cont</p> <p>b. Switch S4 in EXTERNAL position.</p> <p>(1) Switch S5 in OPEN position. +140 VDC ±8% not present.</p> <p>(2) Switch S5 in SHORT position. +78 VDC ±10% not present.</p> <p>c. Switch S4 in COAX position.</p> <p>(1) Switch S5 in OPEN position. +140 VDC ±8% not present.</p> <p>(2) Switch S5 in SHORT position. +78 VDC ±10% not present.</p> <p>11. No voltage between test points F and A. Switches S2 and S3 pressed at the same time.</p>		

Table 6-1. Test Set Troubleshooting - Continued

Fault indication	Probable cause	Corrective action
<p>11 - a. Switch S4 in BULK position.</p> <p>(1) Switch S5 in OPEN position. +500 VDC ±8% not present.</p> <p>(2) Switch S5 in SHORT position. +78 VDC ±10% not present.</p> <p>b. Switch S4 in EXTERNAL position.</p> <p>(1) Switch S5 in OPEN position. +140 VDC ±8% not present.</p> <p>(2) Switch S5 in SHORT position. +78 VDC ±10% not present.</p> <p>c. Switch S4 in COAX position.</p> <p>(1) Switch S5 in OPEN position. +140 VDC ±8% not present.</p>	<p>a, b, and c.</p> <p>(1) Switch S5 defective. Lamp L2 open.</p> <p>Resistor R5 open.</p> <p>(2) Switch S5 defective. Lamp L2 open. Defective wiring.</p>	<p>a, b, and c.</p> <p>Replace switch S5 (para 6-9). Replace lamp L2 (para 5-6). Replace resistor R5 (para 6-22).</p> <p>Check wiring for continuity.</p>

Table 6-1. Test Set Troubleshooting - Continued

Fault indication	Probable cause	Corrective action
11 - (2) Switch S5 cont in SHORT position. +78 VDC ±10% not present.		
12. No voltage between test points G and A. Switches S2 and S3 pressed at the same time.		
a. Switch S4 in BULK position.	a. (1) Lamp L2 open.	Replace lamp L2 (para 5-6).
(1) Switch S5 in OPEN position. +500 VDC ±8% not present.	(2) Resistor R4 and/or R5 open. Lamp L2 open.	Replace resistor R4 and/or R5 (para 6-22).
(2) Switch S5 in SHORT Position. +10 VDC ±10% not present.	Defective wiring. L2 lampholder defective.	Check wiring for continuity. Replace L2 lampholder (para 6-8).
b. Switch S4 in EXTERNAL and COAX position. (2)	b. (1) Lamp L2 open. Resistor R5 open,	Replace lamp L2 (para 5-6). Replace resistor R5 (para 6-22).
(1) Switch S5 in OPEN position. +140 VDC ±8% not present.	Defective wiring. continuity. L2 lampholder defective.	Check wiring for Replace L2 lampholder (para 6-8).

Table 6-1. Test Set Troubleshooting - Continued

Fault indication	Probable cause	Corrective action
<p>12 - (2) Switch S5 cont in SHORT position. +10 VDC ±10% not present.</p>		
<p>13. No voltage at output jacks. Press switches S2 and S3 at the same time.</p>		
<p>a. Switch S4 in BULK position.</p>		
<p>(1) Switch S6 in TIP position. At BULK- EXT jack: +500 VDC ±8% not present. At BULK jack TIP: +500 VDC 8% not present.</p>	<p>a. (1) BULK-EXT jack.</p> <p>Lamp L2 open.</p> <p>L2 lampholder.</p> <p>Switch S6.</p> <p>BULK jack,</p> <p>Switch S4.</p>	<p>a. (1) Replace BULK- EXT jack (para 6-15). Replace lamp L2 (para 5-6). Replace lamp- holder L2 (para 6-8). Replace switch S6 (para 6-9). Replace bulk jack (para 6-16). Replace switch S4 (para 6-11).</p>
<p>(2) Switch S6 in RING position. At BULK jack RING: +500 VDC ±8% not present.</p>	<p>(2) BULK jack.</p> <p>Lamp L2 open.</p> <p>L2 lampholder.</p> <p>Switch S6.</p> <p>Switch S4</p>	<p>(2) Replace BULK jack (para 6-16). Replace lamp L2 (para 5-6). Replace L2 lampholder (para 6-8). Replace switch S6 (para 6-9). Replace switch S4 (para 6-11).</p>

Table 6-1. Test Set Troubleshooting - Continued

Fault indication	Probable cause	Corrective action
<p>13 - b. cont Switch S4 in EXTERNAL position. At EXTERNAL jack: +140 VDC ±8% not present.</p>	<p>b. EXTERNAL jack. Switch S4. Lamp L2. L2 lampholder.</p>	<p>b. Replace EXTERNAL jack (para 6-15). Replace switch S4 (para 6-11). Replace lamp L2 (para 5-6). Replace L2 lamp-holder (para 6-8).</p>
<p>c. Switch S4 in COAX position. (1) Switch S6 in TIP position. At COAX Jack (center): +140 VDC ±8% not present.</p>	<p>c. COAX jack. Switch S6. Switch S4. Lamp L2. L2 lampholder.</p>	<p>c. Replace COAX jack (para 6-17). Replace switch S6 (para 6-9). Replace switch S4 (para 6-11). Replace lamp L2 (para 5-6). Replace L2 lamp-holder (para 6-8).</p>
<p>(2) Switch S6 in RING position. At COAX jack (inner ring): +140 VDC not present.</p>	<p>Defective wiring.</p>	<p>Check wiring for continuity.</p>

Table 6-2. Test Set Checkout Procedure

Test instructions	Normal indication
<p style="text-align: center;">NOTE Test point location (fig. FO-2 and FO-3)</p>	
<p>1. <u>Resistance measurements</u></p>	
<p style="text-align: center;">CAUTION</p>	
<p>Disconnect test set from AC power before making resistance measurements.</p>	
<p>a. Using a digital multimeter (see Maintenance Allocation Chart, appendix D) set to the RX100 scale, connect meter leads to test points A and B (AC plug). Switch S1 to ON position.</p>	<p>40 ohms +10%</p>
<p>b. Connect leads of DVM to points C and D (circuit board).</p>	<p>280 ohms +20%</p>
<p>c. Connect positive lead to test point C, common lead to GRD. Switch S5 to SHORT position. Set DVM to RX10K scale.</p>	<p>Greater than 300K ohms</p>
<p>d. Connect common lead to test point C, positive lead to GRD. Switch S5 to SHORT position. Set DVM to RX1 scale.</p>	<p>Less than 100 ohms</p>
<p>e. Connect positive lead to test point E, common lead to GRD. Switch S5 to SHORT position. Set DVM to RX10K scale.</p>	<p>Greater than 300K ohms</p>
<p>f. Connect common lead to test point E, positive lead to GRD. Switch S5 to SHORT position. Set DVM to RX100 scale.</p>	<p>Less than 5K ohms</p>
<p>g. Connect positive lead to test point F, common lead to GRD. Switch S5 to SHORT position. Set DVM to RX10K scale.</p>	<p>Greater than 300K ohms</p>

Table 6-2. Test Set Checkout Procedure - Continued

Test instructions	Normal indication
h. Connect common lead to test point F, positive lead to GRD. Switch S5 to SHORT position. Set DVM to RX10K scale.	
(1) Switch S4 to BULK position.	(1) 50K ohms (approx)
(2) Switch S4 to EXTERNAL position.	(2) 65K ohms (approx)
i. Connect positive lead to test point F, common lead to test point E. Set DVM to RX10K scale.	
(1) Switch S4 to BULK position.	(1) 35K ohms +/-5%
(2) Switch S4 to EXTERNAL position.	(2) 45K ohms +/-5%
j. Connect DVM leads between test points I and J. Set DVM to RX100 scale.	10K ohms +/-5%
k. Connect DVM leads between test points J and K. Set DVM to RX100 scale.	5K ohms +/-5%
1.	
(1) Connect positive lead to test point G, common lead to GRD. Switch S5 to OPEN position. Set DVM to RX10K scale. Switch S4 to BULK position.	(1) Infinite ohms
(2) Connect common lead to test point G, positive lead to GRD. Set DVM to RX1 scale.	(2) Less than 100 ohms
(3) Switch S4 to EXTERNAL position. Set DVM to RX10K scale.	(3) Infinite ohms
(4) Connect common lead to test point G, positive lead to GRD. Set DVM to RX1 scale.	(4) Less than 100 ohms

Table 6-2. Test Set Checkout Procedure - Continued

Test instructions	Normal indication
m. (1) Connect positive lead to test point H, common lead to GRD. Switch S5 to OPEN position. Set DVM to RX10K scale. Switch S4 to BULK position. (2) Connect common lead to test point H, positive lead to GRD. Set DVM to RX1 scale.	(1) Infinite ohms (2) Less than 100 ohms
n. (1) Connect positive lead to test point D, common lead to GRD. Switch S5 to SHORT position. Set DVM to RX10K scale. (2) Connect common lead to test point D, positive lead to GRD. Set DVM to RX100 scale.	(1) Greater than 300K ohms (2) Less than 2K ohms
2. Voltage Measurements	
<p style="text-align: center;">NOTE</p> The following voltage measurements will be made with the test set connected through a variac (see Maintenance Allocation Chart, appendix D) into a 115 VAC (50, 60 or 400 Hz) power outlet.	
a. Adjust the variac for 115 VAC. Set within the accuracy of the DVM.	115 VAC
b. Connect test set power cord into variac. Turn power switch to ON position.	Red lamp should light

Table 6-2. Test Set Checkout Procedure - Continued

Test instructions	Normal indication
c. Set DVM to AC and connect positive test lead to test point C, negative lead to test point D.	280 VAC +/-2%
d. (1) Set DVM to DC and connect positive test lead to test point C, negative lead to GRD. Switch S5 to SHORT position. Switches S2 and S3 <u>not</u> pressed.	(1) +390 VDC +/-5%
(2) Press switches S2 and S3 at same time.	(2) +340 VDC +/-5%
e. Connect positive lead to test point E. Switch S5 to SHORT position.	
(1) Switches S2 and S3 <u>not</u> pressed.	(1) +770 VDC +/-5%
(2) Switches S2 and S3 pressed at same time.	(2) +680 VDC +/-5%
f. Connect positive lead to test point F. Switch S5 to SHORT position.	
(1) Switches S2 and S3 <u>not</u> pressed.	(1) +770 VDC +/-5%
(2) Switch S4 to BULK position. Press switches S2 and S3 at same time.	(2) +210 VDC +/-5%
(3) Switch S4 to EXTERNAL position and press switches S2 and S3 at same time.	(3) +78 VDC +/-10%
g. Connect positive lead to test point I, negative lead to GRD. Switch S4 to BULK position. Switch S5 to OPEN position.	
<p>CAUTION Take readings within 10 seconds.</p>	
	<p>6-13</p>

Table 6-2. Test Set Checkout Procedure - Continued

Test instructions	Normal indication
(1) Press switches S2 and S3 at same time.	(1) +500 VDC +/-8%
(2) Switch S5 to SHORT position. Press switches S2 and S3 at same time.	(2) +210 VDC +/-10%
(3) Switch S4 to EXTERNAL position. Switch S5 to OPEN position. Press switches S2 and S3 at same time.	(3) +140 VDC +/-8%
(4) Switch S5 to SHORT position. Press switches S2 and S3 at same time.	(4) +78 VDC +/-10%
(5) Switch S4 to COAX position. Switch S5 to OPEN position. Press switches S2 and S3 at same time.	(5) +140 VDC +/-8%
(6) Switch S5 to SHORT position. Press switches S2 and S3 at same time.	(6) +78 VDC +/-10%
h. Connect positive lead to test point G, negative lead to GRD.	
(1) Switch S5 to OPEN position. Switch S4 to BULK position. Press switches S2 and S3 at same time.	(1) +500 VDC +/-8%
<p style="text-align: center;">CAUTION</p> <p>Take readings within 10 seconds.</p>	
(2) Switch S4 to EXTERNAL position. Press switches S2 and S3 at same time.	(2) +140 VDC +/-8%
(3) Switch S4 to COAX position. Press switches S2 and S3 at same time.	(3) +140 VDC +/-8%
i. Connect positive lead to test point H, negative lead to GRD.	

Table 6-2. Test Set Checkout Procedure - Continued

Test instructions	Normal indication
<p>(1) Switch S5 to OPEN position. Switch S4 to BULK position. Press switches S2 and S3 at same time.</p> <p>CAUTION Take readings within 10 seconds.</p>	<p>(1) +140 VDC +/-8%</p>
<p>(2) Switch S4 to EXTERNAL position. Press switches S2 and S3 at same time.</p>	<p>(2) +140 VDC +/-8%</p>
<p>(3) Switch S4 to COAX position. Press switches S2 and S3 at same time.</p>	<p>(3) +140 VDC +/-8%</p>
<p>j. Connect positive lead to test point J, negative lead to GRD.</p>	
<p>(1) Switch S4 to BULK position. Switch S5 to OPEN position. Press switches S2 and S3 at same time.</p> <p>CAUTION Take readings within 10 seconds.</p>	<p>(1) +500 VDC +/-8%</p>
<p>(2) Switch S5 to SHORT position. Press switches S2 and S2 at same time.</p>	<p>(2) +78 VDC +/-10%</p>
<p>(3) Switch S4 to EXTERNAL position. Switch S5 to OPEN position. Press switches S2 and S3 at same time.</p>	<p>(3) +140 VDC +/-10%</p>
<p>(4) Switch S5 to SHORT position. Press switches S2 and S3 at same time.</p>	<p>(4) +78 VDC +/-10%</p>
<p>(5) Switch S4 to COAX position. Switch S5 to OPEN position. Press switches S2 and S3 at same time.</p>	<p>(5) +140 VDC +/-10%</p>
<p>(6) Switch S5 to SHORT position. Press switches S2 and S3 at same time.</p>	<p>(6) +78 VDC +/-10%</p>

Table 6-2. Test Set Checkout Procedure - Continued

Test instructions	Normal indication
k. Connect positive lead to test point K, negative lead to GRD.	
(1) Switch S4 to BULK position. Switch S5 to OPEN position. Press switches S2 and S3 at same time.	(1) +500 VDC +/-8%
<p style="text-align: center;"><u>CAUTION</u> Take readings within 10 seconds.</p>	
(2) Switch S5 to SHORT position. Press switches S2 and S3 at same time.	(2) +10 VDC +/-10%
(3) Switch S4 to EXTERNAL position. Switch S5 to OPEN position. Press switches S2 and S3 at same time.	(3) +140 VDC +/-8%
(4) Switch S5 to SHORT position. Press switches S2 and S3 at same time.	(4) +10 VDC +/-10%
(5) Switch S4 to COAX position. Switch S5 to OPEN position. Press switches S2 and S3 at same time.	(5) +140 VDC +/-10%
(6) Switch S5 to SHORT position. Press switches S2 and S3 at same time.	(6) +10 VDC +/-10%
1. Connect positive lead to test point D, negative lead to GRD.	
(1) Switch S5 in SHORT position. Switches S2 and S3 not pressed.	(1) +385 VDC +/-5%
(2) Switches S2 and S3 pressed at same time.	(2) +340 VDC +/-5%
m. Test is completed, disconnect equipment.	

Section III. REPAIR

6-5. Introduction. This section describes the repair instructions for the test set and consists of removal and replacement procedures for electrical and mechanical items. Repair procedures are divided into three areas: panel assembly repair, circuit board repair and cable assembly repair. Visual aids for the repair procedures are provided in the form of parts location diagrams (fig. 6-1 and 6-2) and wiring diagram (fig. FO-3).

CAUTION

Before performing any removal or replacement procedures, ensure that there are no external connections made to the test set.

6-6. Panel Assembly Repair. The panel assembly repair consists of removal and replacement procedures for the indicators, rotary switch, and toggle switches. The following paragraphs describe the removal and replacement procedures for these items.

6-7. Removal Ad Replacement Procedures. Refer to figures 6-1 and 6-2 for component location during the following removal and replacement procedures.

6-8. Lampholder. Any of the two lampholders (L1 and L2) located on the test set panel assembly may be removed and replaced by performing the following procedures:

a. Removal. Perform the following procedure to remove lampholder:

- (1) Remove the eight Phillips head screws securing panel assembly to case and remove panel assembly.
- (2) Tag, unsolder and remove connecting wires from lampholder.
- (3) Remove nut and lock washer securing lampholder to panel assembly and remove lampholder.

b. Replacement. Perform the following procedure to replace lampholder:

- (1) Insert lampholder into panel assembly and secure with nut and lock washer.
- (2) Install and solder wires as tagged.
- (3) Replace panel assembly and secure to case with the eight Phillips head screws.

6-9. Toggle Switch. Any toggle switch (S1, S2, S3, S5 and S6) located on the test set panel assembly may be removed and replaced by performing the following procedures.

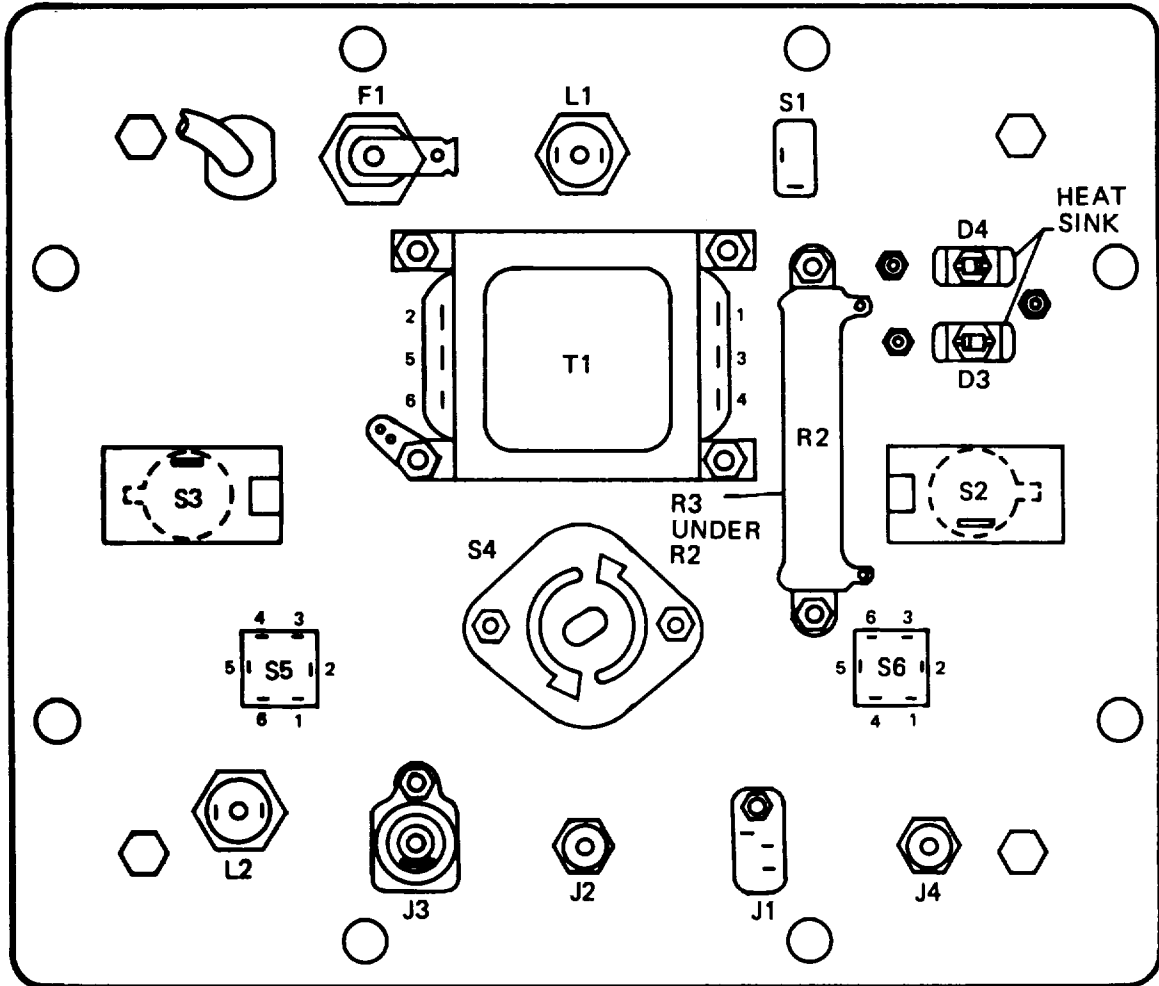

3989-81

Figure 6-1. Panel Assembly Parts Location

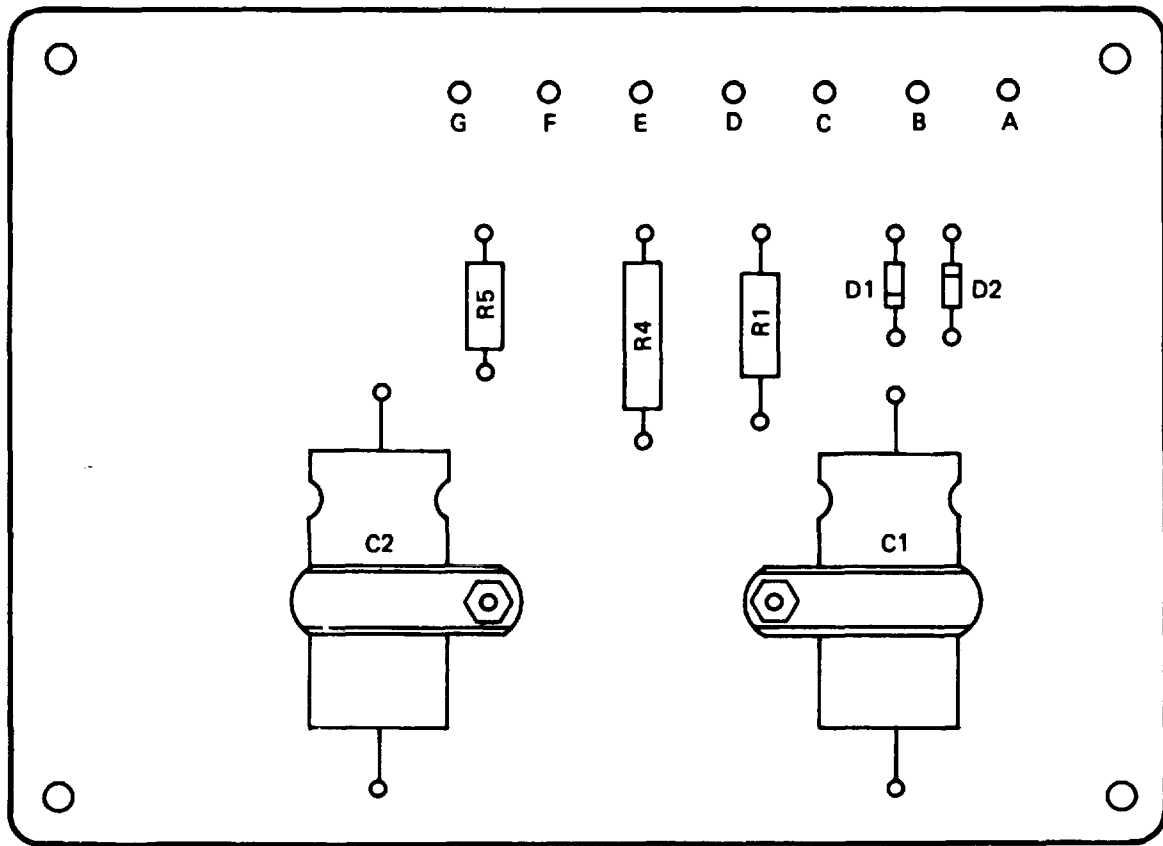

4007-81

Figure 6-2. Circuit Board Parts Location

- a. Removal. Perform the following procedure to remove any of the five toggle switches:
 - (1) Remove the panel assembly as described in paragraph 6-8a.
 - (2) Tag, unsolder, and remove connecting wires to toggle switch.
 - (3) Remove nut and lockwasher securing toggle switch to panel assembly and remove toggle switch.
- b. Replacement. Perform the following procedure to replace either of the five toggle switches:
 - (1) Install toggle switch and lockwasher on panel assembly and secure with nut.
 - (2) Install and solder wires as tagged.
 - (3) Replace panel assembly as described in paragraph 6-8b.

6-10. Zener Diode. The zener diode(s) (D3 and D4) may be removed and replaced by performing the following procedures.

- a. Removal. Perform the following procedure to remove a zener diode:
 - (1) Remove the panel assembly as described in paragraph 6-8a.
 - (2) Unsolder diode leads on heat sink and remove diode.

CAUTION

Overheating may destroy the thermal conductivity of the copper pad bonding agent or loosen the pad.

- b. Replacement. Perform the following procedure to replace the zener diode:
 - (1) Install zener diode with associated heat sink (OBSERVE POLARITY) and solder.

CAUTION

Repeated heating may destroy thermal conductivity of copper pad bonding agent or loosen the pad.

- (2) Replace panel assembly as described in paragraph 6-8b.

6-11. Rotary Switch. The rotary switch (S4) located on the test set panel assembly may be removed and replaced by performing the following procedures.

- a. Removal. Perform the following procedure to remove the rotary switch:

- (1) Remove the panel assembly as described in paragraph 6-8a.
- (2) Remove the four nuts, flat washers and lockwasher securing circuit board to top of the four hexagonal spaces and lay circuit board to the side.
- (3) Loosen set screw securing rotary switch knob (fig. 3-1) to rotary switch and remove knob.
- (4) Tag, unsolder, and remove connecting wires to rotary switch.
- (5) Remove nut and lockwasher securing rotary switch to panel assembly and remove rotary switch.

b. Replacement. Perform the following procedure to replace the rotary switch:

- (1) Install rotary switch on the panel assembly and secure with nut and lock washer. Ensure rotary switch guide pin fits in panel hole.
- (2) Install and solder wires as tagged.
- (3) Install knob on rotary switch shaft and secure with set screw.
- (4) Install circuit board on top of hexagonal spacers and secure with the four nuts, flat washers and lockwasher
- (5) Replace panel assembly as described in paragraph 6-8b.

6-12. Power Transformer. The power transformer (T1) may be removed and replaced by performing the following procedures.

a. Removal. Perform the following procedure to remove power transformer:

- (1) Remove panel assembly as described in paragraph 6-8a.
- (2) Remove circuit board assembly as described in paragraph 6-11a.
- (3) Tag, unsolder, and remove connecting wires to power transformer.
- (4) Remove four screws, lockwasher and nuts securing power transformer to panel assembly and remove power transformer.

b. Replacement. Perform the following procedure to replace power transformer:

- (1) Install power transformer on panel assembly and secure with the four screws, lockwasher and nuts.

- (2) Install and solder wires as tagged.
- (3) Replace circuit board assembly as described in paragraph 6-11b.
- (4) Replace panel assembly as described in paragraph 6-8b.

6-13. Fuse Holder. The fuse holder may be removed and replaced by performing the following procedures.

a. Removal. Perform the following procedure to remove the fuse holder from the panel assembly:

- (1) Remove panel assembly as described in paragraph 6-8a.
- (2) Tag and unsolder the wires on the fuse holder.
- (3) Remove the nut securing the fuse holder to panel assembly and remove holder.

b. Replacement. Perform the following procedure to replace fuse holder on the panel assembly:

- (1) Insert fuse holder in the panel assembly and secure with nut.
- (2) Install and solder wires as tagged.
- (3) Replace panel assembly as described in paragraph 6-8b.

6-14. Resistors. The resistors (R2 and R3) may be removed and replaced by performing the following procedures.

a. Removal. Perform the following procedure to remove the resistors from the panel assembly:

- (1) Remove panel assembly described in paragraph 6-8a.
- (2) Remove circuit board as described in paragraph 6-11a.
- (3) Tag and unsolder the wires on the resistor(s).
- (4) Remove the two nuts, lockwasher screws and spacers (two spacers separate R2 and R3) securing the resistor to the panel assembly and remove resistor(s).

b. Replacement. Perform the following procedure to replace either resistor:

- (1) Install resistor(s) on the front panel and secure with two screws, nuts, lockwasher and spacers.
- (2) Solder wires as tagged.

(3) Replace circuit board assembly as described in paragraph 6-11b.

(4) Replace panel assembly as described in paragraph 6-8b.

6-15. Banana Jacks. The banana jacks (J2 and J4) may be removed and replaced by performing the following procedures.

a. Removal. Perform the following procedure to remove either banana jack:

(1) Remove panel assembly as described in paragraph 6-8a.

(2) Unsolder the wire connected to banana jack.

(3) Remove the nut securing banana jack to panel assembly and remove banana jack.

b. Replacement. Perform the following procedure to replace banana jack on panel assembly:

(1) Insert banana jack in panel assembly and secure with nut.

(2) Solder wire on banana jack.

(3) Replace panel assembly as described in paragraph 6-8b.

6-16. Telephone Jack. The telephone jack (J1) may be removed and replaced by performing the following procedures.

a. Removal. Perform the following procedure to remove the telephone jack from the panel assembly:

(1) Remove the panel assembly as described in paragraph 6-8a.

(2) Tag and unsolder wires on the jack.

(3) Remove the nut, screw and lockwasher securing jack to panel assembly and remove jack.

b. Replacement. Perform the following procedure to replace the telephone jack:

(1) Insert jack in panel assembly and secure with screw, nut and lockwasher .

(2) Solder wires as tagged,.

(3) Replace panel assembly as described in paragraph 6-8b.

6-17. Coax Jack. The coax jack (J3) may be removed and replaced by performing the following procedures.

a. Removal. Perform the following procedure to remove the coax jack from the panel assembly:

- (1) Remove the panel assembly as described in paragraph 6-8a.
- (2) Tag and unsolder wires on the jack.
- (3) Remove the nut, screw and lockwasher securing jack to panel assembly and remove jack.

b. Replacement. Perform the following procedure to replace the coax jack:

- (1) Insert jack in panel assembly and secure with screw, nut and lockwasher.
- (2) Solder wires as tagged.
- (3) Replace panel assembly as described in paragraph 6-8b.

6-18. Power Cord. Power cord repair consists of removal and replacement procedures for the power cord.

a. Removal. Perform the following procedure to remove the power cord from the panel assembly:

- (1) Remove the panel assembly as described in paragraph 6-8a.
- (2) Remove circuit board assembly as described in paragraph 6-11a
- (3) Unsolder the white lead from the AC POWER switch (S1).
- (4) Unsolder the black lead from transformer (T1).
- (5) Unsolder the green lead from lug secured to transformer.
- (6) Remove plastic clamp securing power cord to panel assembly and remove cord through opening.

b. Replacement. Perform the following procedure to replace power cord on the panel assembly:

- (1) Insert power cord through plastic clamp and then insert cord and clamp into opening on panel assembly.
- (2) Solder the white lead to AC POWER switch.
- (3) Solder the black lead to transformer.
- (4) Solder the green lead to lug secured to transformer.
- (5) Replace circuit board assembly as described in paragraph 6-11b.

(6) Replace panel assembly as described in paragraph 6-8b.

6-19. Circuit Board Repair. Circuit board repair consists of removal and replacement procedures for the filter capacitors, resistors and diode rectifiers. The following paragraphs describe the removal and replacement procedures for these items. Refer to figure 6-2 for component location.

6-20. Filter Capacitor. Filter capacitors (C1 and C2) may be removed and replaced by performing the following procedures.

a. Removal. Perform the following procedure to remove filter capacitor from the circuit board:

(1) Remove panel assembly as described in paragraph 6-8a.

CAUTION

Discharge capacitor before removing.

(2) Remove circuit board assembly as described in paragraph 6-11a.

(3) Remove nut, screw and lockwasher securing capacitor clamp to circuit board.

(4) Unsolder capacitor leads and remove capacitor.

CAUTION

Overheating may destroy thermal conductivity of copper pad bonding agent or loosen pad.

b. Replacement. Perform the following procedure to replace filter capacitor:

NOTE

Ensure leads are connected to correct polarity.

(1) Insert filter capacitor into clamp and secure clamp with screw, nut and lockwasher.

(2) Insert capacitor leads into holes in copper pad. DO NOT OVERHEAT COPPER PAD.

(3) Solder leads (clip off excess lead length).

(4) Install circuit board assembly as described in paragraph 6-11b.

(5) Replace panel assembly as described in paragraph 6-8b.

6-21. Diode Rectifier. The diode rectifier(s) (D1 and D2) may be removed and replaced by performing the following procedures.

a. Removal. Perform the following procedure to remove the diode rectifier(s) from the circuit board:

- (1) Remove panel assembly as described in paragraph 6-8a.
- (2) Remove circuit board as described in paragraph 6-20a.
- (3) Unsolder diode rectifier and remove rectifier.

CAUTION

Overheating may destroy thermal conductivity of copper pad bonding agent or loosen pad.

b. Replacement. Perform the following procedure to replace diode rectifier:

- (1) Insert diode rectifier leads into holes in copper pad. OBSERVE CORRECT POLARITY.
- (2) Solder leads.

CAUTION

Overheating may loosen copper pad or destroy new diode rectifier.

- (3) Install circuit board as described in paragraph 6-20b.
- (4) Replace panel assembly as described in paragraph 6-8b.

6-22. Resistors. The resistor(s) (R1, R4 and R5) may be removed and replaced by performing the following procedures.

a. Removal. Perform the following procedure to remove the resistor from the circuit board:

- (1) Remove panel assembly as described in paragraph 6-8a.
- (2) Remove circuit board as described in paragraph 6-20a.
- (3) Unsolder resistor leads from the copper pad and remove resistor. DO NOT OVERHEAT COPPER PAD.

b. Replacement. Perform the following procedure to replace resistor:

- (1) Insert resistor leads in copper pad.
- (2) Solder leads using 20-watt (maximum) soldering iron. DO NOT OVERHEAT COPPER PAD. Clip off excess lead length.

(3) Install circuit board as described in paragraph 6-20b.

(4) Replace panel assembly as described in paragraph 6-8b.

6-23. Cable Assembly Repair. When inspection of a test cable used with the test set discloses that a cable or connector is damaged, follow the maintenance procedure for the three cables listed below.

a. Telephone Patch Cable TT-126. Maintenance of this cable consists of removal of the cable and replacement with a new cable.

b. Red Booted Alligator Cable Model 1959-36. Maintenance of this cable consists of removal and replacement of the alligator clip end and/or banana jack end. Perform steps (1) through (5) for replacing alligator clip. Perform steps (6) through (9) for replacing banana jack.

Alligator clip end:

- (1) Slide rubber boot back from alligator clip.
- (2) Clip off damaged alligator clip.
- (3) Strip enough insulation from end of wire.
- (4) Loop under screw on clip, tighten screw and push rubber boot over clip.
- (5) If clip is crimp type, crimp wire on clip and slide boot over clip.

Banana jack end:

- (6) Remove damaged banana jack from wire.
- (7) Strip enough insulation from end of wire.
- (8) Insert wire into banana jack until it bottoms out and tighten screw (or solder).
- (9) Screw threaded insulator on banana jack.

c. TWINAX Cable Assembly Type PTW-36-78 (fig. 6-3). Follow maintenance procedure described below:

- (1) Remove wrench crimp nut (1) on connector and slide connector from cable.
- (2) Cut off end of wire flush.
- (3) Place nut (1) onto cable (see fig. 6-3a).
- (4) Strip outer jacket (A) and braid (B) as shown in figure 6-3b.

- (5) Comb out braid and bend outward to allow free entry of cone (2). This will prevent cone from forcing braid up under jacket.
- (6) Cut filler (G) out as shown in figure 6-3c.
- (7) Push cone dielectric (3) into cavity of cone (2).
- (8) Insert conductors (D and F) into cone assembly. Push edge of cone under braid (B). Tapered cone will flare out braid and jacket. Continue to push cable into cone until braid (G) is flush with edge of cone (2).
- (9) Install insulation washer (9) over conductors (D and F) and seat against cone dielectric (3).
- (10) Cut conductor (F) 11/32 inch long measured from surface of washer (9), or dielectric (3) - strip dielectric (E) back 3/32 inch (fig. 6-3d).
- (11) Cut conductor (D) 11/32 inch long measured from surface of washer (9), or dielectric (3) - strip dielectric (C) back 3/16 inch (fig. 6-3d).
- (12) Tin conductor (F).
- (13) Push notched insert (10) over conductor (F), with conductor (D) folded at a right angle to allow notched insert (10) to seat flat against washer (9), or dielectric (3).
- (14) Solder pin (4), seated against notched insert (10), to conductor (F).
- (15) Slip dielectric (5) over pin (4). Slip shield (6) over pin assembly and seat against washer (9).
- (16) Wrap conductor (D) between shield ridges and solder neatly. (Do not allow solder to extend above ridges.)
- (17) Push insert (7) over shield (6), and seat against insulating washer (9), or dielectric (3).
- (18) Assemble connector body assembly over insert (7) and engage with nut.
- (19) Wrench tighten to 30-40 in. lbs. torque.
- (20) Perform the following continuity check using digital multimeter:
 - Between pin D and F (see figure 6-3).
 - Between Pin D and connector body.
 - Between Pin F and connector body.

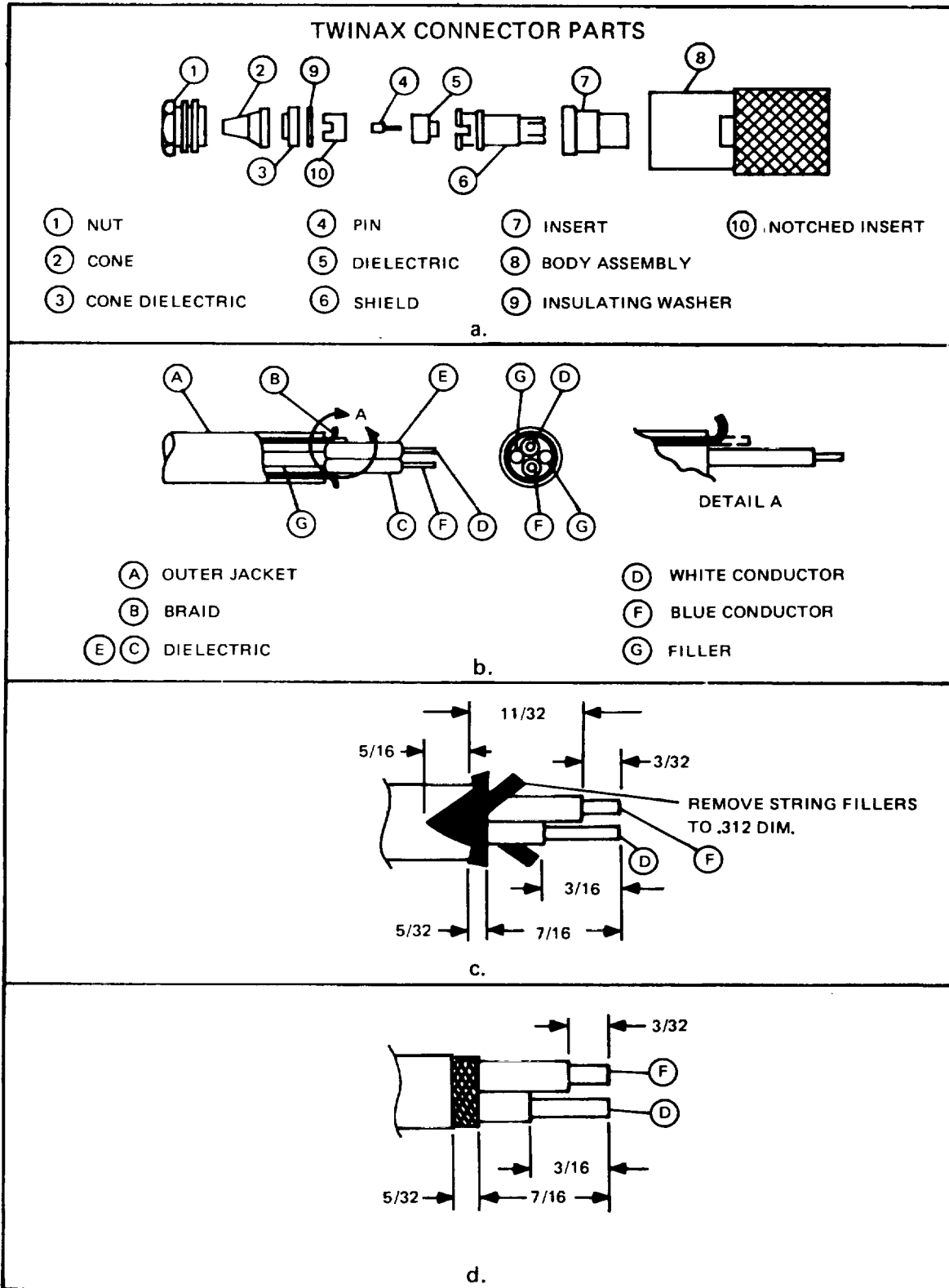

4006-81

Figure 6-3. TWINAX Cable Assembly PTW-36-78

**APPENDIX A
REFERENCES**

DA Pam 310-1	Consolidated Index of Army Publications and Blank Forms,
SB 11-573	Painting and Preservation Supplies Available for Field Use for Electronics Command Equipment.
TM 11-5805-681-34-1 EE119-BA-MMI-O10/E154 TTC 39/TO 31W2-2TTC39-2-1	Intermediate Maintenance Manual: Central Office Telephone, Automatic AN/TTC-39(V) (*) (To be published).
TM 11-5805-683-34-1 EE119-AA-MMI-O10/E154 TTC39/TO 31W2-2TYC39-12-1	Intermediate Maintenance Manual: Control, Message Switching Central, Automatic AN/TYC-39(V) (*) (To be published).
TM 11-6625-3023-24P ET904-AA-PLL-010/E154 TS3684/TO 33A1-8-901-4-1	Test Set, Electric Surge Arrestors TS-3684/T (To be published).
TM 38-750	The Army Maintenance Management System (TAMMS).
TM 746-10	Field Instructions for Painting and Preserving Electronics Command Equipment.

A-1/(A-2 blank)

APPENDIX B

MAINTENANCE ALLOCATION

Section I. INTRODUCTION

B-1. General. This appendix provides a summary of the maintenance operations for the Test Set, Electric Surge Arrestors TS-3684()/T. It authorizes categories of maintenance for specific maintenance functions on repairable items and components and the tools and equipment required to perform each function.

B-2. Maintenance Concept. Three levels of maintenance shall be utilized for the equipment a follows:

Organizational Level
General Support Level
Depot Level.

a. Organization Maintenance. That maintenance which is the responsibility of and performed by a using organization on its assigned equipment. Its phases normally consist of inspecting, servicing, lubricating, and adjusting, and the replacement o parts, minor assemblies and subassemblies. This level is designated by an O in the Maintenance Category columns in Section II.

b. General Support Maintenance. That maintenance which is the responsibility of and performed by designated maintenance activities to support lower level activities. General Support Maintenance is normally accomplished in fixed shops. This level is designated by an H in the Maintenance Category columns in Section II.

c. Depot Maintenance. That maintenance which is the responsibility of and performed by designated maintenance activities, to augment stocks of serviceable material, and to support lower level activities by the use of more extensive shop facilities, equipment and personnel of higher technical skills than are available at the lower level of maintenance. Its phases normally consist of inspection, test, repair, modification, alteration, modernization, conversion, overhaul reclamation, rebuild of parts, assemblies, subassemblies, components, equipment end items, and weapon systems; and the manufacture of critical nonavailable parts. Depot Maintenance is normally accomplished in fixed shops. This level is designated by a D in the Maintenance Category columns in Section II.

B-3. Maintenance Function. Maintenance functions for the Test Set, Electric Surge Arrestor TS-3684()/T are defined as follows:

a. Inspect. To determine the serviceability of an item

by comparing its physical, mechanical, and/or electrical characteristics with established standards through examination.

b. Test. To verify serviceability and to detect incipient failure by measuring the mechanical or electrical characteristics of an item and comparing those characteristics with prescribed standards.

c. Service. Operations required periodically to keep an item in proper operating condition, i.e., to clean (decontaminate), to preserve, to drain, to paint, or to replenish fuel, lubricants, hydraulic fluids, or compressed air supplies.

d. Adjust. To maintain, within prescribed limits, by bringing into proper or exact position, or by setting the operating characteristics to the specified parameters.

e. Align. To adjust specified variable elements of an item to bring about optimum or desired performance.

f. Calibrate. To determine and cause corrections to be made or to be adjusted on instruments or test measuring and diagnostic equipments used in precision measurement. Consists of comparisons of two instruments, one of which is a certified standard of known accuracy, to detect and adjust any discrepancy in the accuracy of the instrument being compared.

g. Install. The act of emplacing, seating, or fixing into position an item, part, or module (component or assembly) in a manner to allow the proper functioning of the equipment or system.

h. Replace. The act of substituting a serviceable like type part, subassembly, or module (component or assembly) for an unserviceable counterpart.

i. Repair. The application of maintenance service (inspect, test, service, adjust, align, calibrate, or replace) or other maintenance actions (welding, grinding, riveting, straightening, facing, remachining, or resurfacing) to restore serviceability to an item by correcting specific damage, fault, malfunction, or failure in a part, subassembly, module (component or assembly), end item, or system.

j. Overhaul. That maintenance effort (service/ action) necessary to restore an item to a completely serviceable/operational condition as prescribed by maintenance standards (i.e., DMWR) in appropriate technical publications. Overhaul is normally the highest degree of maintenance performed by the

Army. Overhaul does not normally return a to like new condition.

k. *Rebuild.* Consists of those services/actions necessary for the restoration of unserviceable equipment to a like new condition in accord with original manufacturing standards. Rebuild the highest degree of materiel maintenance to Army equipment. The rebuild operation the act of returning to zero those age measurements (hours, miles, etc.) considered(classifying Army equipments/components.

- C Operator/Crew
- O Organizational
- F Direct Support
- H General Support
- D Depot.

e. *Column 5, Tools and Equipment.* Column 5 specifies, by code, those common tool sets (not individual tools), and special tools, test, and support equipment required to perform the designated function.

f. *Column 6, Remarks.* Column 6 contains an alphabetic code which leads to the remark in Section IV, Remarks, which is pertinent to the item opposite the particular code.

B-4.. Column Entries.

a. *Column 1, Group Number.* Column 1 group numbers, the purpose of which is to identify components, assemblies, subassemblies, and modules with the next higher assembly.

b. *Column 2, Component/Assembly.* Column 2 contains the noun names of components, assemblies, subassemblies, and modules for which maintenance is authorized.

c. *Column 3, Maintenance Function.* Column 3 lists the functions to be performed on the item listed in Column 2. When items are listed w maintenance functions, it is solely for the purpose of having the group numbers in the MAC a RPSTL coincide.

d. *Column 4, Maintenance Category.* Column 4 specifies by the listing of a worktime figure appropriate subcolumn(s), the lowest level o maintenance authorized to perform the fun listed in Column 3. This figure represents the time required to perform that maintenance function at the indicated category of maintenance If the number or complexity of the tasks within listed maintenance function vary at different maintenance categories, appropriate worktime figures will be shown for each category. The number of task-hours specified by the work figure represents the average time required restore an item (assembly, subassembly, con module, end item or system) to a serviceability condition under typical field operating conditions. This time includes preparation time, troubleshooting time, and quality assurance, control time in addition to the time require(perform the specific tasks identified for the maintenance functions authorized in the maintenance allocation chart. Subcolumns of Column 4 are as follows:

B-5. Tool and Test Equipment Requirements (Section III).

a. *Tool or Test Equipment Reference Code.* The numbers in this column coincide with the numbers used in the tools and equipment column of the MAC. The numbers indicate the applicable tool or test equipment for the maintenance functions.

b. *Maintenance Category.* The codes in this column indicate the maintenance category allocated the tool or test equipment.

c. *Nomenclature.* This column lists the noun name and nomenclature of the tools and test equipment required to perform the maintenance functions.

d. *National/NA TO Stock Number.* This column lists the National/NATO stock number of the specific tool or test equipment.

e. *Tool Number.* This column lists the manufacturer's part number of the tool followed by the Federal Supply Code for manufacturers (5digit) in parentheses.

B-6. Remarks (Section IV).

a. *Reference Code.* This code refers to the appropriate item in Section II, Column 6.

b. *Remarks.* This column provides the required explanatory information necessary to clarify items appearing in Section II.

**SECTION II. MAINTENANCE ALLOCATION CHART
FOR
TEST SET, ELECTRIC SURGE ARRESTORS TS-384()/T**

(1) GROUP NUMBER	(2) COMPONENT ASSEMBLY	(3) MAINTENANCE FUNCTION	(4) MAINTENANCE CATEGORY					(5) TOOLS AND EQUIPMENT	(6) REMARKS	
			C	O	F	H	D			
00	TEST SET, ELECTRIC SURGE ARRESTOR TSA3684/T	INSPECT TEST REPLACE REPAIR OVERHAUL REBUILD		0.1 0.1 0.1 0.1			1.5	60.0 80.0	5 1,2,3, 4,5,6 1,2,3, 4,5,6	A B C
01	PANEL ASSEMBLY	REPAIR REPAIR		0.1			1.5	1,5 1,2,5		C
02	PRINTED CIRCUIT BOARD ASSEMBLY	REPAIR					1.5	1,2,4, 5,6		
03	CABLES	REPAIR		0.5				1,3,5		

**SECTION III. TOOL AND TEST EQUIPMENT REQUIREMENTS
FOR
TEST SET, ELECTRIC SURGE ARRESTORS TS3684()/T**

TOOL OR TEST EQUIPMENT REF CODE	MAINTENANCE CATEGORY	NOMENCLATURE	NATIONAL/ NATO STOCK NUMBER	TOOL NUMBER
1	O,H,D	TOOL KIT, TK-105/G	5180-00-610-8177	
2	H,D	MULTIMETER, ME-450U	6625-00-149-6301	
3	O,H,D	TOOL KIT, WIRE WRAP/ ELECTRICAL CONNECTOR		
4	HD	TOOL KIT, PRINTED CIRCUIT CARD REPAIR	3439-00-196-0703	
5	O,H,D	DIGITAL MULTIMETER, AN/USM- 451	6625-00-168-0585	
6	H,D	VARIAC	5950-00-617-9242	

SECTION IV. REMARKS

Reference Code	Remarks
A B C	VISUAL EXTERNAL PERFORM SELF-TEST BEFORE EMPLOYMENT OF UNIT AS TEST EQUIPMENT ORGANIZATIONAL REPAIR IS LIMITED TO LAMP AND FUSE REPLACEMENT

APPENDIX C

COMPONENTS OF END ITEM LIST

Section I. INTRODUCTION

C-1. Scope. This appendix lists integral components of and basic issue items for the TS-3684/T to help you inventory items required for safe and efficient operation.

C-2. General. This Components of End Item List is divided into the following sections:

a. Section II. Integral Components of the End Item. These items, when assembled, comprise the TS-3684/T and must accompany it whenever it is transferred or turned in. The illustrations will help you identify these items.

b. Section III. Basic Issue Items. These are the minimum essential items required to place the TS-3684/T in operation, to operate it, and to perform emergency repair. Although shipped separately packed, they must accompany the TS-3684/T during operation and whenever it is transferred between accountable officers. The illustrations will assist you with hard-to-identify items. This manual is your authority to requisition replacement BII, based on TOE/MTOE authorization of the end item.

C-3. Explanation of Columns.

a. Illustration. This column is divided as follows:

(1) Figure Number. Indicates figure number of the illustration on which the item is shown.

(2) Item Number. The number used to identify item called out in the illustration.

b. National Stock Number. Indicates the National stock number assigned to the item and which will be used for requisitioning.

c. Part Number. Indicates the primary number used by the manufacturer, which controls the design and characteristics of the item by means of its engineering drawings, specifications, standards, and inspection requirements to identify an item or range of items.

d. Description. Indicates the Federal item name and, if required, a minimum description to identify the item.

e. Location. The physical location of each item listed is given in this column. The lists are designed to inventory all items in one area of the major item before moving on to an adjacent area.

f. Quantity Required (Qty Reqd). This column lists the quantity of each item required for a complete major item.

g. Quantity. This column is left blank for use during an inventory. Under the Recv'd column, list the quantity you actually receive on your major item. The Date columns are for your use when you inventory the major item at a later date; such as for shipment to another site.

SECTION II. INTEGRAL COMPONENTS OF END ITEM

(1) ILLUSTRATION		(2)	(3)	(4)	(5)	(6)	(7)	(8) QUANTITY			
(a) FIGURE NO.	(b) ITEM NO.	NATIONAL STOCK NUMBER	PART NO.	DESCRIPTION	LOCATION	USABLE ON CODE	QTY REQD	RCV-D	DATE	DATE	DATE
C-1	1			Test Set, ESA			1				
C-1	2		TS-3684/U (80058)	Test Lead			1				
C-1	3		1959-36 (05276)	Test Cable			1				
C-1	4		TT-126 (82384)	Test Cable			1				
			PTW-36-78 (14949)								

TECHNICAL MANUAL, TM 11-6625-3023-14

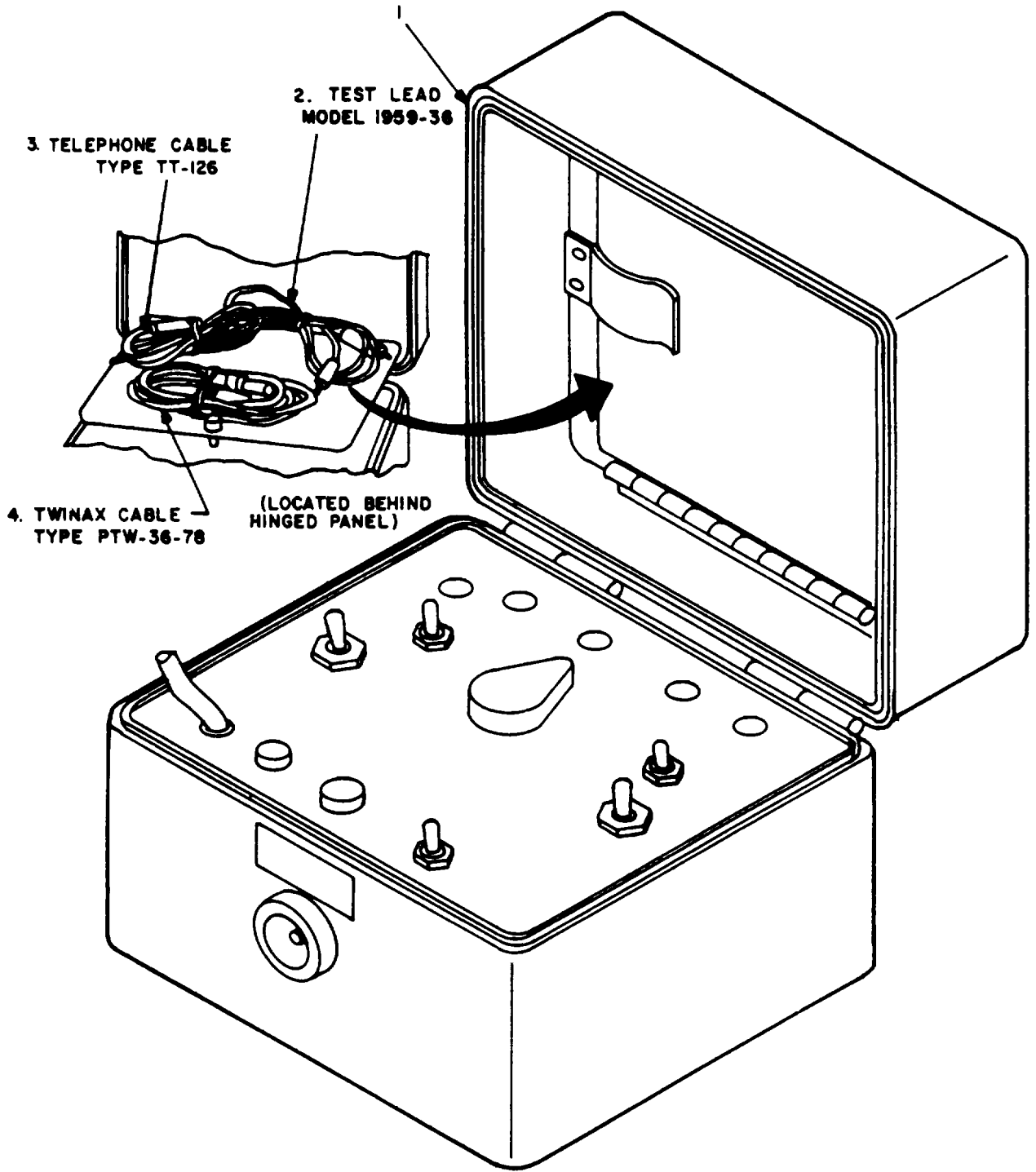

Figure C-1. Test Set, ESA TS-3684/T

APPENDIX E

EXPENDABLE SUPPLIES AND MATERIALS LIST

Section I. INTRODUCTION

E-1. Scope. This appendix lists expendable supplies and materials you will need to operate and maintain the TS-3684/T. These items are authorized to you by CTA 50-970, Expendable Items (Except Medical, Class V, Repair Parts, and Heraldic Items).

E-2. Explanation of Columns.

a. Column 1 - Item Number. This number is assigned to the entry in the listing and is referenced in the narrative instructions to identify the material (e.g., 'Use cleaning compound, item 5, App. D").

b. Column 2 -Level. This column identifies the lowest level of maintenance that requires the listed item.

C - Operator/Crew

O - Organizational Maintenance

F - Direct Support Maintenance

H - General Support Maintenance

c. Column 3 - National Stock Number. This is the National stock number assigned to the item; use it to request or requisition the item.

d. Column 4 - Description. Indicates the Federal item name and, if required, a description to identify the item. The last line for each item indicates the part number followed by the Federal Supply Code for Manufacturer (FSCM) in parentheses, if applicable.

e. Column 5 - Unit of Measure (U/M). Indicates the measure used in performing the actual maintenance function. This measure is expressed by a two-character alphabetical abbreviation (e.g., ea, in, pr). If the unit of measure differs from the unit of issue, requisition the lowest unit of issue that will satisfy your requirements.

E-3. Special Information.

National stock numbers (NSN's) that are missing from section II have been applied for and will be added to this manual by future change/revision when they are entered in the Army Master Data File (AMDF). Until the NSN's are established and published, submit exception requisitions to: Commander, US Army Communications Electronics Command and Fort Monmouth, ATTN: DRSEL-MM, Fort Monmouth, New Jersey for the part required to support your equipment.

SECTION II. ITEM NUMBER	(2) LEVEL	(3) NATIONAL STOCK NUMBER	(4) DESCRIPTION	(5) U/M
1	0	8305-267-3015	Cloth, cotton, cheesecloth	ROLL
2	0		Enamel, semigloss, dark green MIL-E-46061	QT
3	0	8010-582-5318	Primer, zinc chromate	QT
4	0		Sandpaper, Fine, No. 0000	SH
5	0		Soft-bristle brush	EA
6	0	6810-00-292-9625	Trichlorotrifluoroethane OT620 (81349)	OZ
E-2				

By Order of the Secretaries of the Army, the Navy, and the Air Force:

E. C. MEYER
General, United States Army
Chief of Staff

Official:
ROBERT M. JOYCE
Major General, United States Army
The Adjutant General

G. B. SHICK
Rear Admiral United States Navy
Commander, Naval Electronic
Systems Command

Official:
JAMES P. MULLINS
General, USAF, Commander, Air Force
Logistics Command

CHARLES A GABRIEL, *General USAF*
Chief of Staff

DISTRIBUTION:

To be distributed in accordance with Special List.

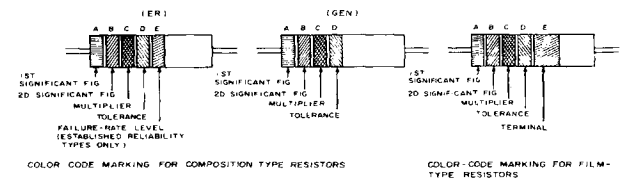
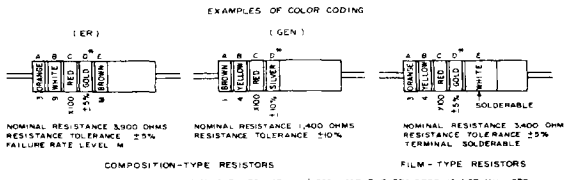

TABLE 1
COLOR CODE FOR COMPOSITION TYPE AND FILM TYPE RESISTORS

BAND A		BAND B		BAND C		BAND D		BAND E		TERM
COLOR	FIRST SIGNIFICANT FIGURE	COLOR	SECOND SIGNIFICANT FIGURE	COLOR	MULTIPLIER	COLOR	RESISTANCE TOLERANCE (PERCENT)	COLOR	FAILURE RATE LEVEL	
BLACK	0	BLACK	0	BLACK	1	BROWN	±10 (COMP TYPE ONLY)	BROWN	M1-D	
BROWN	1	BROWN	1	BROWN	10	RED	±5 (NOT APPLICABLE TO ESTABLISHED RELIABILITY)	RED	R1-D	
RED	2	RED	2	RED	100	ORANGE		ORANGE	O1-D	
ORANGE	3	ORANGE	3	ORANGE	1,000	SILVER		YELLOW	S1-O (DD)	SOLDERABLE
YELLOW	4	YELLOW	4	YELLOW	10,000			WHITE		
GREEN	5	GREEN	5	GREEN	100,000	GOLD				
BLUE	6	BLUE	6	BLUE	1,000,000	RED				
PURPLE (VIOLET)	7	PURPLE (VIOLET)	7							
GRAY	8	GRAY	8	SILVER	0.01					
WHITE	9	WHITE	9	GOLD	0.1					

BAND A — THE FIRST SIGNIFICANT FIGURE OF THE RESISTANCE VALUE (BANDS A THRU D SHALL BE OF EQUAL WIDTH)
 BAND B — THE SECOND SIGNIFICANT FIGURE OF THE RESISTANCE VALUE
 BAND C — THE MULTIPLIER (THE MULTIPLIER IS THE FACTOR BY WHICH THE TWO SIGNIFICANT FIGURES ARE MULTIPLIED TO YIELD THE NOMINAL RESISTANCE VALUE)
 BAND D — THE RESISTANCE TOLERANCE
 BAND E — WHEN USED ON COMPOSITION RESISTORS, BAND E INDICATES ESTABLISHED RELIABILITY FAILURE RATE LEVEL, PERCENT FAILURE PER 1,000 HOURS; ON FILM RESISTORS THIS BAND SHALL BE APPROXIMATELY 1/2 TIMES THE WIDTH OF OTHER BANDS, AND INDICATES TYPE OF TERMINAL RESISTORS IDENTIFIED BY NUMBERS AND LETTERS (THESE ARE NOT COLOR CODED)
 SOME RESISTORS ARE IDENTIFIED BY THREE OR FOUR DIGIT ALPHA NUMERIC DESIGNATORS THE LETTER R IS USED IN PLACE OF A DECIMAL POINT WHEN FRACTIONAL VALUES OF AN OHM ARE EXPRESSED FOR EXAMPLE
 2R7 = 2.7 OHMS 10R0 = 10.0 OHMS

FOR WIRE-WOUND TYPE RESISTORS COLOR CODING IS NOT USED, IDENTIFICATION MARKING IS SPECIFIED IN EACH OF THE APPLICABLE SPECIFICATIONS



A COLOR CODE MARKING FOR MILITARY STANDARD RESISTORS

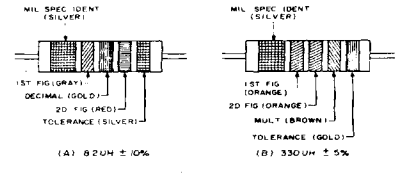

COLOR CODING FOR TUBULAR ENCAPSULATED RF CHOKES. AT A, AN EXAMPLE OF THE CODING FOR AN 8.2UH CHOKE IS GIVEN. AT B, THE COLOR BANDS FOR A 330UH INDUCTOR ARE ILLUSTRATED

TABLE 2
COLOR CODING FOR TUBULAR ENCAPSULATED RF CHOKES

COLOR	SIGNIFICANT FIGURE	MULTIPLIER	INDUCTANCE TOLERANCE (PERCENT)
BLACK	0	1	
BROWN	1	10	1
RED	2	100	2
ORANGE	3	1,000	3
YELLOW	4		
GREEN	5		
BLUE	6		
VIOLET	7		
GRAY	8		
WHITE	9		
NOISE		30	
SILVER		10	
GOLD	DECIMAL POINT	5	

MULTIPLIER IS THE FACTOR BY WHICH THE TWO COLOR FIGURES ARE MULTIPLIED TO OBTAIN THE INDUCTANCE VALUE OF THE CHOKE COIL

B COLOR CODE MARKING FOR MILITARY STANDARD INDUCTORS. 4010-81

Figure FO-1. ① Standard Color Coding Chart (sheet 1 of 2)

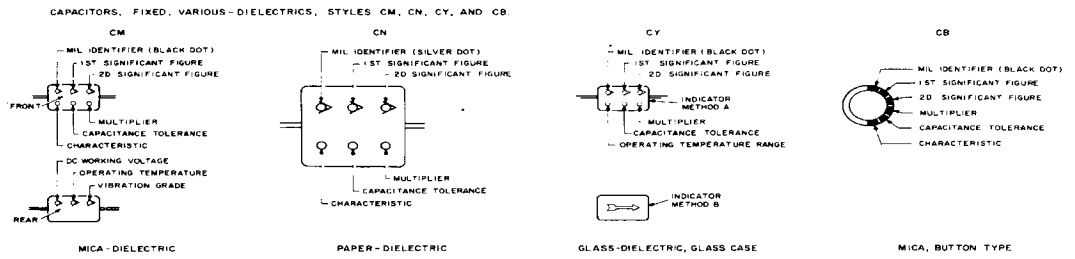

TABLE 3 - FOR USE WITH STYLES CM, CN, CY AND CB

COLOR	MIL ID	1ST SIG FIG	2D SIG FIG	MULTIPLIER	CAPACITANCE TOLERANCE				CHARACTERISTIC	DC WORKING VOLTAGE	OPERATING TEMP RANGE	VIBRATION GRADE
					CM	CN	CY	CB				
BLACK	0	0	0	1			±20%	±20%			-55° to +70°C	10-55 Hz
BROWN	1	1	1	10					B	A		
RED	2	2	2	100	±2%		±2%	±2%	C	E	0	
ORANGE	3	3	3	1,000	±30%		±30%		D	D	300	-55° to +125°C
YELLOW	4	4	4	10,000					E			10-2,000 Hz
GREEN	5	5	5				±5%		F		300	-55° to +125°C
BLUE	6	6	6									-55° to +125°C
PURPLE (VIOLET)	7	7	7									
GRAY	8	8	8									
WHITE	9	9	9									
GOLD				0.1			±5%	±5%				
SILVER	CN			0.01	±10%	±10%	±10%	±10%				

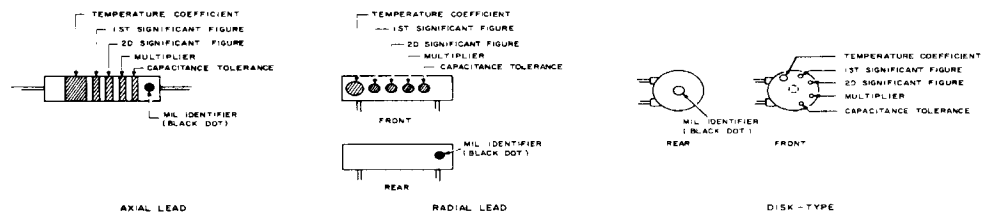

TABLE 4 - TEMPERATURE COMPENSATING, STYLE CC

COLOR	TEMPERATURE COEFFICIENT*	1ST SIG FIG	2D SIG FIG	MULTIPLIER	CAPACITANCE TOLERANCE		MIL ID
					CAPACITANCES OVER 10 UUF	CAPACITANCES 10 UUF OR LESS	
BLACK	0	0	0	1		±2.0 UUF	CC
BROWN	-30	1	1	10	±1%		
RED	-80	2	2	100	±2%	±0.25 UUF	
ORANGE	-150	3	3	1,000			
YELLOW	-220	4	4				
GREEN	-350	5	5		±2.5%	±0.5 UUF	
BLUE	-470	6	6				
PURPLE (VIOLET)	-750	7	7				
GRAY		8	8	0.01 [#]			
WHITE		9	9	0.1 [#]	±10%		
GOLD	+100			0.1		±1.0 UUF	
SILVER				0.01			

1 THE MULTIPLIER IS THE NUMBER BY WHICH THE TWO SIGNIFICANT (SIG) FIGURES ARE MULTIPLIED TO OBTAIN THE CAPACITANCE IN UUF
 2 LETTERS INDICATE THE CHARACTERISTICS DESIGNATED IN APPLICABLE SPECIFICATIONS MIL-C-5, MIL-C-250, MIL-C-12728, AND MIL-C-10980C RESPECTIVELY
 3 LETTERS INDICATE THE TEMPERATURE RANGE AND VOLTAGE-TEMPERATURE LIMITS DESIGNATED IN MIL-C-110150
 4 TEMPERATURE COEFFICIENT IN PARTS PER MILLION PER DEGREE CENTIGRADE
 # OPTIONAL CODING WHERE METALLIC PIGMENTS ARE UNDESIRABLE

C. COLOR CODE MARKING FOR MILITARY STANDARD CAPACITORS

4011-81

Figure FO-1 (2) Standard Color Coding Chart (sheet 2 of 2)

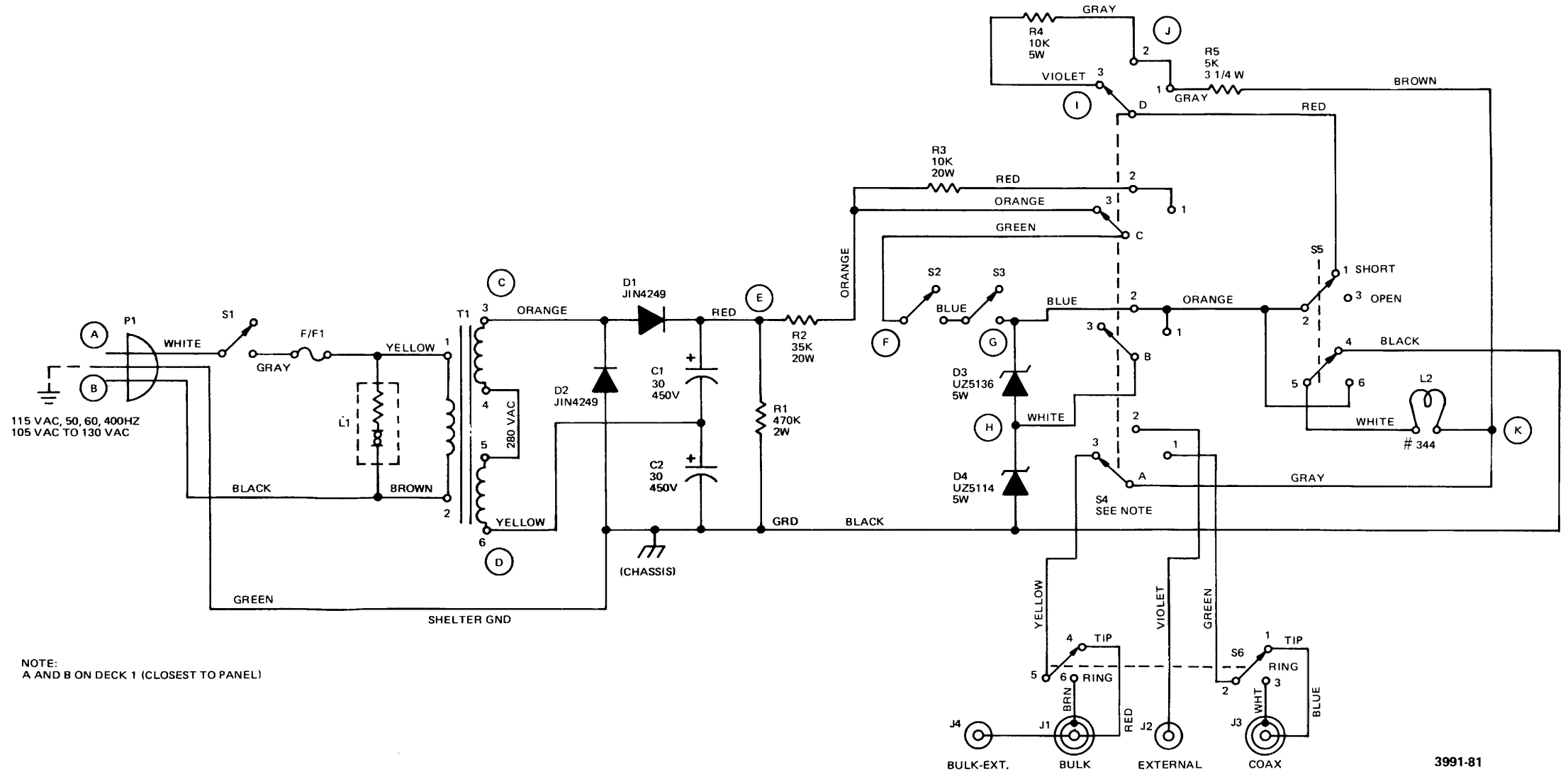

Figure FO-2. ESA Test Schematic Diagram

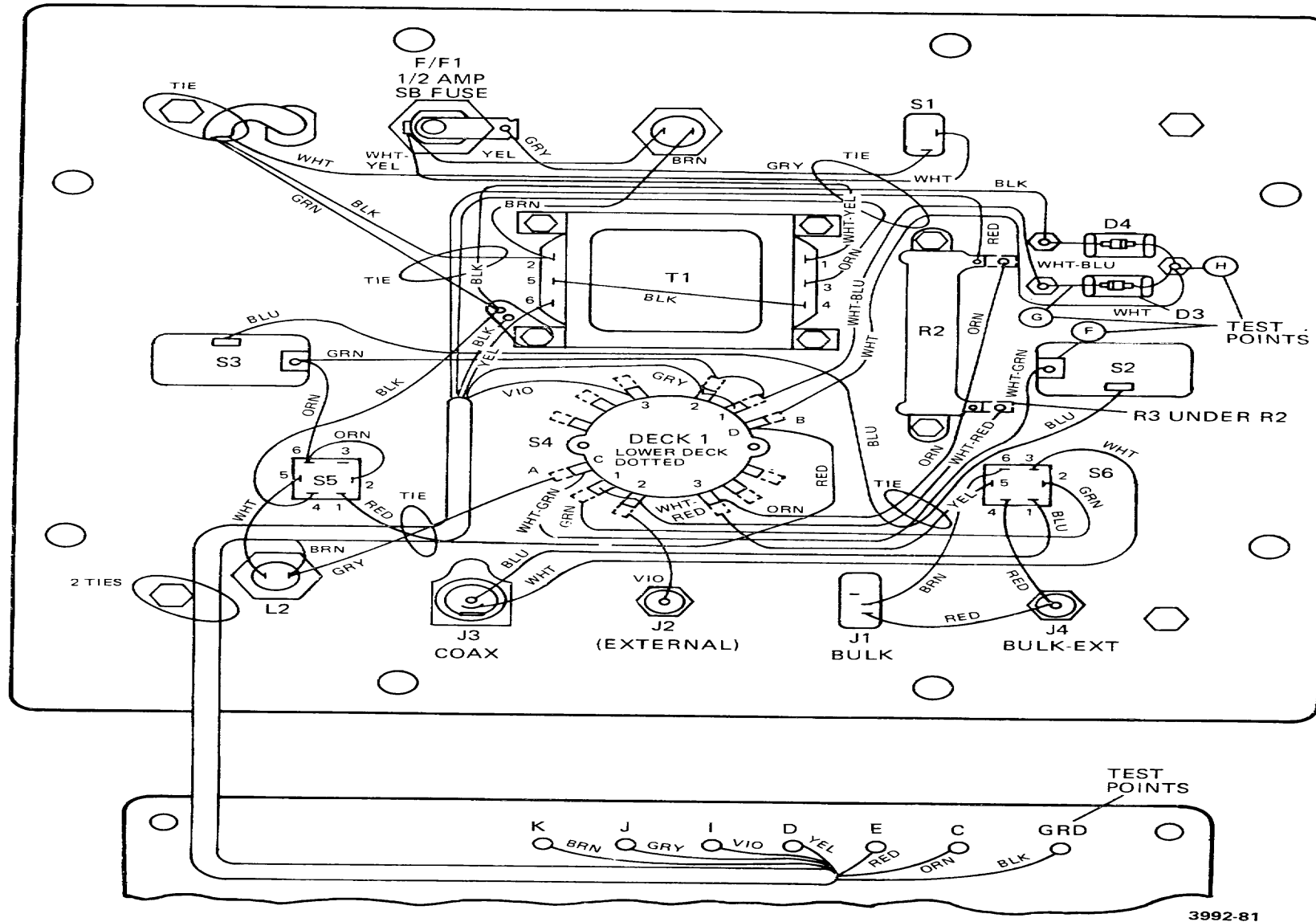

Figure FO-3. Test Set, TS-3684/T
Wiring Diagram

RECOMMENDED CHANGES TO EQUIPMENT TECHNICAL PUBLICATIONS



THEN . . . JOT DOWN THE
DOPE ABOUT IT ON THIS
FORM, CAREFULLY TEAR IT
OUT, FOLD IT AND DROP IT
IN THE MAIL!

SOMETHING WRONG WITH THIS PUBLICATION?

FROM: (PRINT YOUR UNIT'S COMPLETE ADDRESS)

DATE SENT

PUBLICATION NUMBER

TM 11-5825-270-10

PUBLICATION DATE

23 Jul 81

PUBLICATION TITLE

Radio Frequency R-2176/FRN

BE EXACT . . . PIN-POINT WHERE IT IS

PAGE NO.	PARA-GRAPH	FIGURE NO.	TABLE NO.
----------	------------	------------	-----------

IN THIS SPACE TELL WHAT IS WRONG
AND WHAT SHOULD BE DONE ABOUT IT:

TEAR ALONG PERFORATED LINE

PRINTED NAME, GRADE OR TITLE, AND TELEPHONE NUMBER

SIGN HERE:

DA FORM 2028-2
1 JUL 79

PREVIOUS EDITIONS
ARE OBSOLETE.

P.S.—IF YOUR OUTFIT WANTS TO KNOW ABOUT YOUR
RECOMMENDATION MAKE A CARBON COPY OF THIS
AND GIVE IT TO YOUR HEADQUARTERS.

